

Alpha Murphy Bed

(Horizontal Version)



It's like having your own shop!

Assembly Instructions

Questions call 501.753.9699

Designed to exceed International ISO 9002
Standards for Residential Specifications

Install the Murphy Bed

Step 1: Mount the Lift Mechanism

Step 2: Install the springs on the Lift Mechanism

Step 3: Assemble the Bed Cabinet

Step 4: Attach Bed Cabinet Securely to Wall

Step 5: Install the Bed Face Panel Unit

Step 6: Install Handle = Legs - Mechanism Covers - Mattress

Complete Bed Assembly

Install the Murphy Bed

Step 1: Mount the Lift Mechanism

NOTE: On some versions this may have been completed for you. If the mechanism is installed on the vertical, skip to step 3.

1-1: The left and right mechanism hole pattern will line up with the hole pattern on the Side Panel (B). The bolts will be fed through the side that has the counter sinks drilled.

1-2 Hole A will not have a standard nut. It is either a threaded hole or it will use a disk like bolt "Arm Lock Stop". Get Hole A started.

1-3 Insert the bolt in the other holes and loosely tighten onto the nuts.

1-4 Once all are in place securely tighten using the Allen Wrench provided and a 1/2" wrench.

Step 2: Install the springs on the Lift Mechanism

SPRING APPLICATION CHART		
<small>Please Note: These are recommendations only. Actual number of springs required will depend on the total weight of the bed-face unit including the mattress and all bedding.</small>		
BED SIZE	BED PANEL MATERIAL	
	Plywood Core	Particle Board
Single/Twin	4-5 springs per side	5-6 springs per side
Double/Full	6-7 springs per side	7-8 springs per side
Queen	7-8 springs per side	8-9 springs per side
King	9 springs per side	not recommended

After you have completed installing and checking the operation of your bed, you may find it necessary to add or remove springs to achieve the correct lift effort of between 5 to 10 pounds.

There are nine locations for springs. If the bed requires an even number of springs, do not use the center hole (#5 from the top). If the bed requires an odd number of springs, start with the center hole (#5 from the top) and work outward in both directions evenly.

Hook the springs so the open ends are facing outward. You may have to gently pry up the tension arm and slide the spring under and snap them into place in the proper hole, matching the same numbered hole from the top of the mechanism back plate. You should have an equal number of springs on each side of the center hole. Use the same number of springs and the same layout on both the left and right mechanisms.

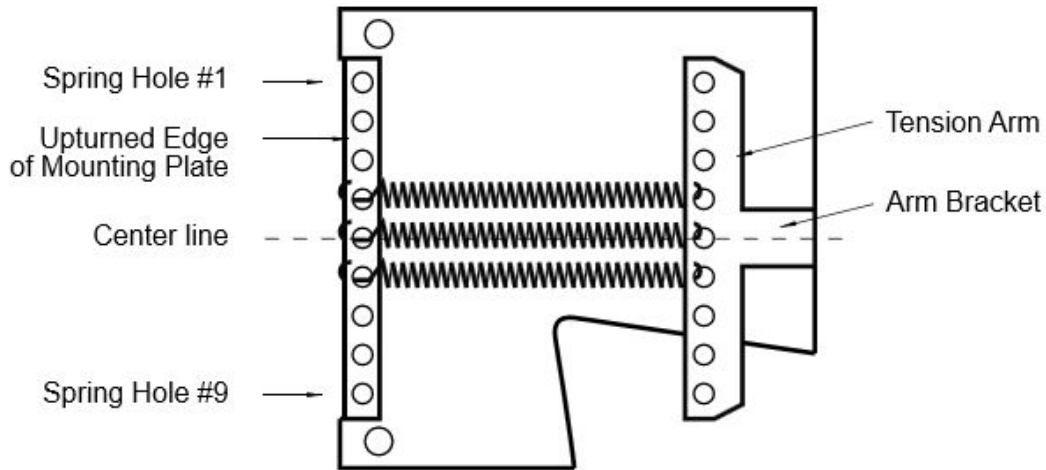

Step 3: Assemble the Bed Cabinet

- If possible, the Bed Cabinet should be assembled in the room where it will be used.
- The following installation will be done with the bed face down on the floor.

Place the verticals finished edge down and dowel holes toward the inside on a clean floor. You may even lay a soft blanket down to protect the finish from being scratched.

Headboard installation

3-1: Insert the headboard dowels into the ends of the headboard (two on each side). No need to measure we've taken that step out of you. With the pocket screw holes facing toward the back, insert the headboard dowels into the side of the verticals. Secure with 1 ½" screws (4 each side).

3-2: Use Angle Brackets to assemble Bottom Rear Stiffener and Bottom Kick & Kick Stiffener in position shown in Figure 6-1 and Figure 6-2. Use two Angle Brackets on each end. Attaching using supplied ¾" screws.

NOTE: The Bottom Rear Stiffener can be moved closer to the front if there is a cutout for base molding on the back of the verticals.

3-3: Attach header as shown in Figure 6-2. Be sure back edge of the header is flush with Front and top of Side Panels. Attach with 1 ½" supplied screws.

3-4: Put 1 ½" screws in the pockets that are in the Top Rear stiffener and the Top Facia Stiffener.

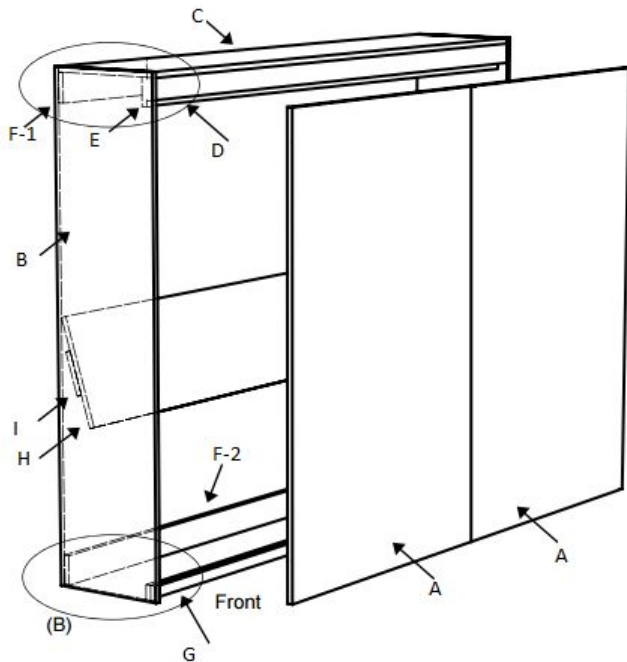

Figure 6-1 **Brackets not shown in the drawing**

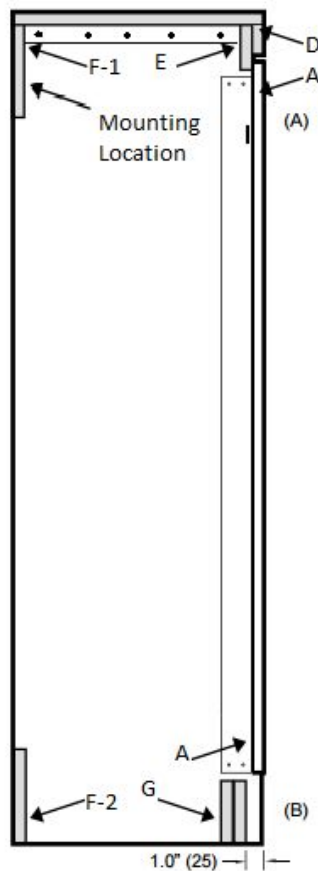

Figure 6-2

Step 4: Attach Bed Cabinet Securely to Wall

We cut out for your base molding so you don't have to remove base molding off the wall. If our cutout was not large enough more may need to be done. Use a jig saw to perform this task.

6-1: Find Studs

Prior to placing cabinet against the wall, locate 3 studs or other wall frame members at the level of the Top Panel (top of bed). Alert: The cabinet must be secured to studs or other wall structural members. If the wall is not a wood stud wall, use metal stud screws, toggle bolts or concrete expansion bolts if necessary.

If you have lights make sure the wire is run in the groove on the back of the right vertical

6-2: Attach to wall

Now that the cabinet is square and plumb, **pre-drill hole in the Top Rear Stiffener at the stud location Secure with 3" screws. Repeat this for two other stud locations.** (see Drawing 9. but instead of brackets you'll drill through the back board on the header). See figure 6-2.

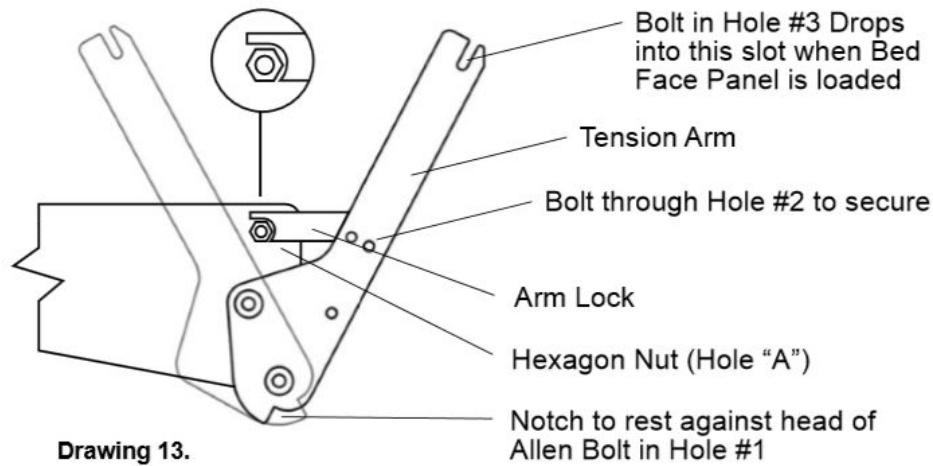

Holding one foot against the bottom front edge of the side panel and using the 13" (330mm) PVC tube, lever the tension arm out until you can set the arm lock to the hex nut at the hole A (see drawing 13.). This is the hex nut at the top front corner of the mechanism.

Tip: If you set the "Arm Lock" on top of the bolt before you pull the Tension Arm back it will fall into place. Do not put your fingers back there to while pulling it back.!

Caution: If possible have a helper assist in the setting of the mechanism and loading of the bed face panel. DO NOT reach behind the tension arm when you are doing the setting procedure.

If you have lights plug in the light bar and attach it from underneath the header using 2-1 1/2" screws.

Step 5: Install the Bed Face Panel Unit

5-8: From hardware card 2, insert a Allen Head Bolts through Hole #1 (6 3/4" from end of side frame) on both left and right side frames (see Drawing 14).

5-8 Also Inserted two 5/16" (M8x20mm) Hex Head Bolts from the outside of the frame through Hole #3. We have left these loose.

5-9 Stand the Bed Face Panel in vertical position between the tension arms, lift evenly until the bolt in Hole #3 drops in the slotted end of each tension arm. Gently tilt the bed face toward you until the Allen Bolts in Hole #1 are completely seated in the bottom notch of the tension arms. Insert the remaining 5/16" (8mm) Hex Head Bolts through tension arms into Holes #2 and fasten with 5/16" (8mm) Nylock Nuts; securely tighten these and the nuts on Hole #3.

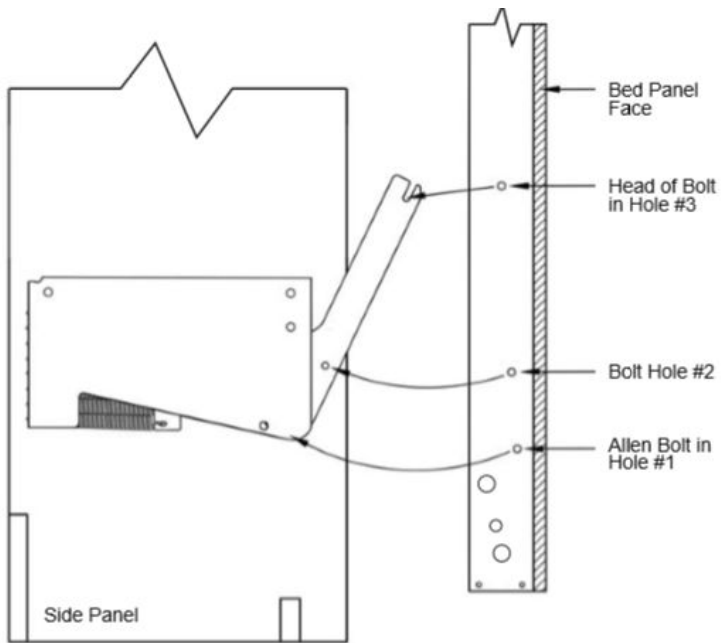

Drawing 14.

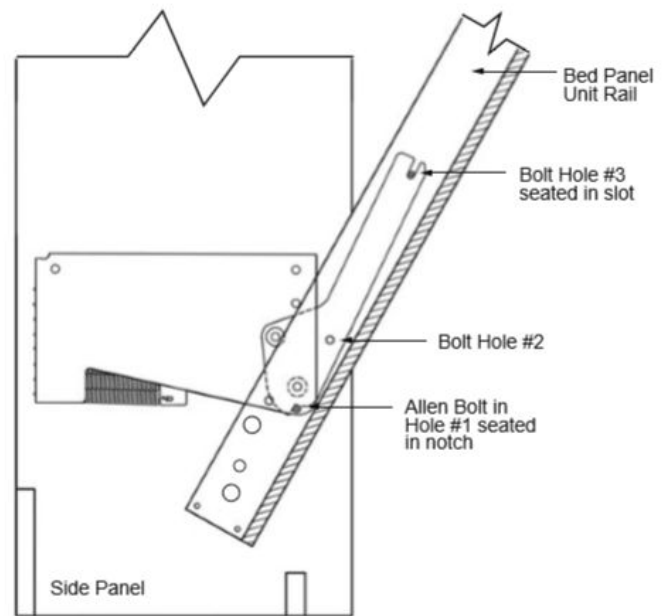

Drawing 15.

5-10 When all bolts are securely tightened, you may tilt the panel outward to approximately 45 degrees to release the arm locks. You will hear a click as they disengage.

Caution:

Hold the Face Panel securely, Do Not let it slam shut. Balance is not achieved until the mattress is loaded in the bed.

Leveling of the bed cabinet is essential. Check the level both side to side and front to back. Proper leveling will facilitate proper closure and exact sight lines of the fit of the Face Panel to the Cabinet.

Step 6: Install Handle = Legs - Mechanism Covers - Mattress

6-1 Install legs with the washers on the inside of the Rails and the Nylon washer on the outside. Tighten nut to have a small amount of friction when leg assembly is rotated from the up to down position.

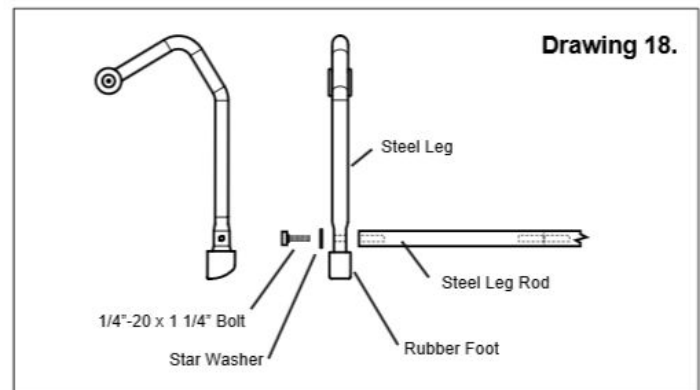
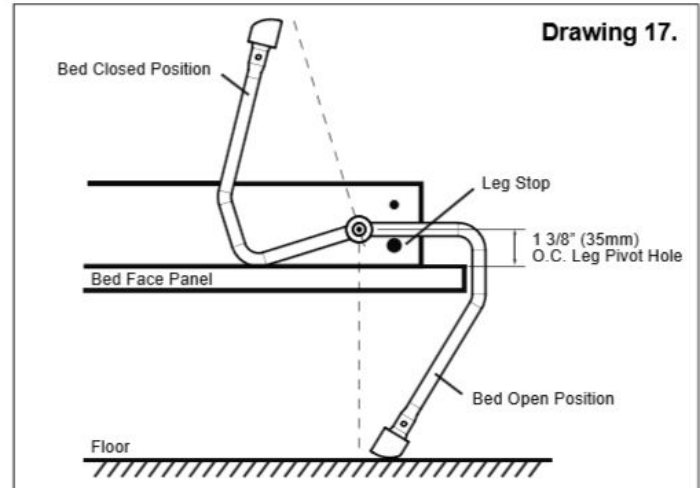
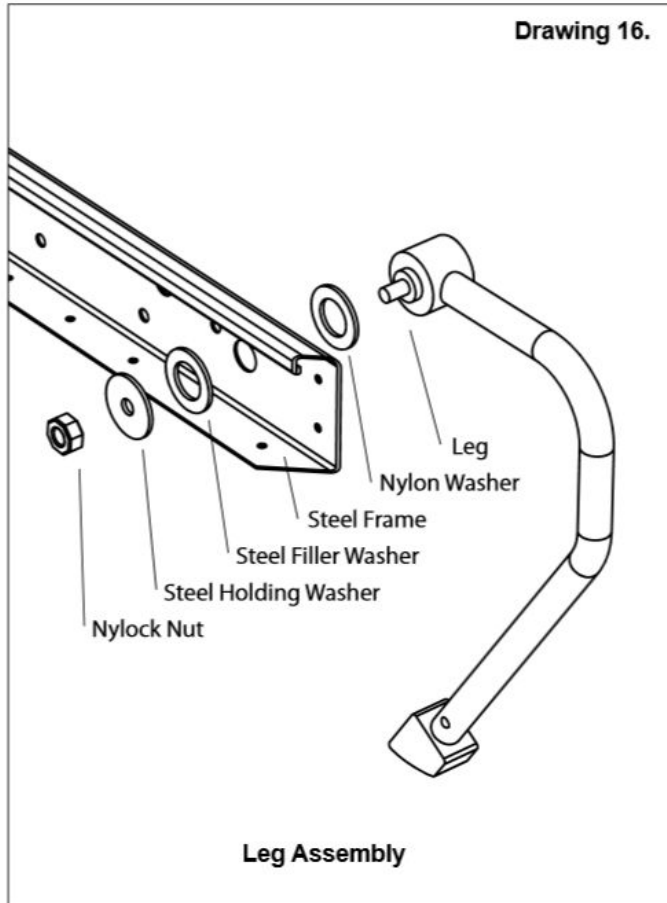

6-2 Install leg connector rod between legs and secure with 1/4"x1 1/4" (M4x32mm) Hex head bolts and star washers. Be sure they are securely tightened so not to become loose.

6-3 Install the mattress and secure with previously installed Nylon Straps.

6-4 Snap the powder coated steel mechanism covers in place - secure with #8x1 1/4" (M4x32mm) black wood screws through the standoff on the backer plate

Complete Bed Assembly

Follow up to Initial Assembly

Check that the Bed Cabinet is level and square so the Bed Face has equal clearance of the Cabinet on both sides, top to bottom. If the Cabinet is leaning to one side, nudge it at the floor level. If the top is uneven, place shims under the Side Panels. If bed is too heavy to operate easily or slams shut, remove the Bed Face Panel and add or subtract springs. At this time, you may decide to use one more or less spring(s) on the left or right side Lift Mechanism. *Vertical example is shown but applies the horizontal unit as well.*

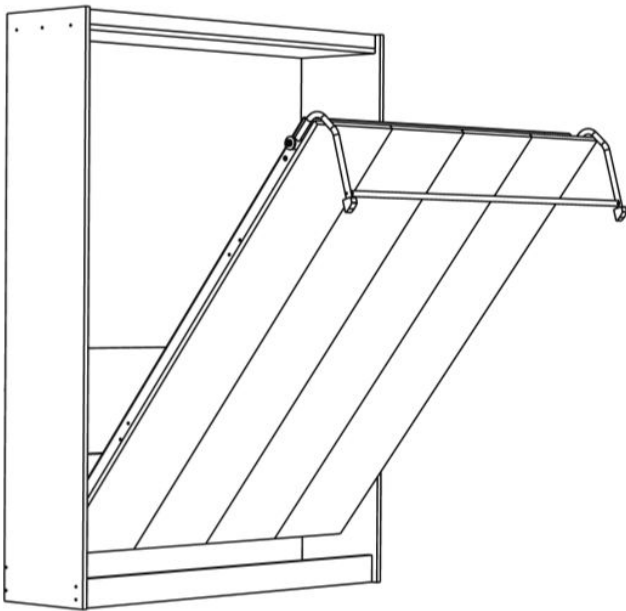

Right Side
Looking through Side Panel.

Office Use only

Note: this is the new design with overlapping top. We shortend the verticals by ¾" and extended the top by ¾"

Steps

- Cut parts on CNC

Qty.	Description	Banding	Other	<input checked="" type="checkbox"/>
4	(A) Bed Face Panels	B2-NE, B1-N, B1-N, B2-NW	Some applications may have a groove cut between the panel. If so W side of all panels except the far left.	
2	(B) Side Panels	B1-E	Countersink holes on outside	
1	(C) Top Panel	B3-ENW	85"	
1	(D) Top Facia	B1-S	83 ½"	
1	(E) Top Facia Stiffener	B1-S	Pocket 2 each end W,E	
1	(F-1) Top Rear Stiffener	B1-S	Pocket 2 each end W,E	
1	(F-2) Bottom Rear Stiffener	4"	B1-N	
1	(G) Kick & Kick Stiffener (1 ½" thick)	4"	Double up and then band (1 ½" thick)	
1	(H) Headboard	B1-N	Domino at 2 ½ , 12 from bottom. Pocket two on each side (far top and bottom only) Center pockets will be on Headboard stiffener.	
1	(I) Head board Stiffener	NB	Two pockets each end	
3	(J) Panel Connectors	3"	Drill double row of screw holes about every 8"	
2	(K) Top Cleats	1"	Drill 4 holes on the end grain and then 5 the other direction	