

# DIY Alpha Murphy Bed

(Vertical Pre-Cut Version)



It's like having your own shop!

**Assembly Instructions**

**Questions call 501.753.9699**

Designed to exceed International ISO 9002  
Standards for Residential Specifications  
Revised 5/20/2017

# Table of Contents

[Step 1: Check Your Components](#)

[Hardware](#)

[Single/Twin](#)

[Full/Double](#)

[Queen](#)

[What we have done for you!](#)

[Step 2: Build the Header](#)

[Step 3: Finish all wood components](#)

[Step 4: Install the springs on the Lift Mechanism](#)

[Step 5: Assemble the Bed Cabinet](#)

[Step 6: Attach Bed Cabinet Securely to Wall](#)

[Step 8: Install the Bed Face Panel Unit](#)

[Lights](#)

[Step 8: Install Handle = Legs - Mechanism Covers - Mattress](#)

[Complete Bed Assembly](#)

## Step 1: Check Your Components

Thank you for your purchase of this DIY Murphy bed. We try to make this projects as easy as possible for you. Take a minute and check your contents.

### Hardware

Qty.	Frame Carton Items	Comments	✓
2	Frame End Sections	Identical Head & Foot	<input type="checkbox"/>
2	Frame Side Sections	Identical, Right or Left	<input type="checkbox"/>
3(5)	Stiffeners - Bed Face (King Size)	Space evenly between Frame Sides	<input type="checkbox"/>
2	Fold-away Legs	One Left - One Right	<input type="checkbox"/>
1	Leg Connector Rod	Stabilizes and Eases Leg Operation	<input type="checkbox"/>
<b>Hardware Card #3</b>			
14	Bolt 10-24x1/2" (M6x12mm) Black	Bolt Frame corners	<input type="checkbox"/>
2	Bolt 10-24x1 1/4" (M6 x 32mm) Black	Bolt Leg Stop Foot corners	<input type="checkbox"/>
16	Nut 10-24 (M6) Black Nylock	Use with #1214 & #1213	<input type="checkbox"/>
4	Angle 1"x1"x1 3/4" (25x25x44mm) Black	Use inside Frame corners	<input type="checkbox"/>
2	1/2"x3/4" (13x19mm) Round Black Cylinder	Use with #1213 as Leg Stop	<input type="checkbox"/>
<b>Hardware Card #4</b>			
2	1 1/2"x5/16" (T1.5x40mm) Black Washer	Secure Leg inside Frame	<input type="checkbox"/>
2	1 1/2"x.765" (T2.5x40mm) Black Washer	Secure Leg inside Frame	<input type="checkbox"/>
2	1 1/2"x.765" (T2.5x40mm) Black Nylon Washer	Between Leg & outside of Frame	<input type="checkbox"/>
2	Nut 5/16" (M8) Black Nylock	Secure Leg inside Frame	<input type="checkbox"/>
2	Bolt 1/4"-20 Black Hex Head	Attach Leg to Leg Rod	<input type="checkbox"/>
2	Star Washer for #1210	Attach Leg to Leg Rod	<input type="checkbox"/>
<b>Hardware Card #5</b>			
1	Nylon Web Strap with Buckle	Secure Mattress to Bed Frame	<input type="checkbox"/>
2	3/4"x1/4" (T1.5x25mm) Washer	Secure Nylon Web Strap to Bed Face Panel under Mattress	<input type="checkbox"/>
2	#8x5/8" (M4x15mm) Wood Screw	Secure Nylon Web Strap	<input type="checkbox"/>
<b>Hardware Card #7 - King size includes 2 bags</b>			
110	#8x5/8" (M4x15mm) Wood Screw	Attach Steel Bed Frame to Bed Face	<input type="checkbox"/>

Qty.	Mechanism Carton Items	Comments	
1	Lift Mechanism - Right Side	Attach to Right Side Panel	<input type="checkbox"/>
1	Lift Mechanism - Left Side	Attach to Left Side Panel	<input type="checkbox"/>
2	#1 Bags containing 9 Springs each	Install correct number in each Mechanism	<input type="checkbox"/>
1	13" Plastic Pipe	Used to set the Lift Mechanisms	<input type="checkbox"/>
<b>Hardware Card #2</b>			
10	Machine Screw 5/16-18 x 1 1/4"	To attach Lift Mechanisms to Side Panels	<input type="checkbox"/>
4	Hex Head Bolt 5/16-18 x 1"	Attach Mechanism to Frame Side section	<input type="checkbox"/>
2	Allen Head Bolt 5/16-18 x 1"	Position Mechanism Arm on Frame Side section	<input type="checkbox"/>
16	Hex Head Nylock Nut	Secure Bolts and Screws	<input type="checkbox"/>
1	Allen Wrench 5/16"	For Allen Head bolts	<input type="checkbox"/>

## Single/Twin

### Overall Cabinet Dimensions

**Mattress Size:** 39" x 75" (12" Max Thickness) 44 ½"w x 85 ¼"h x 16"d (Projection from wall: 85")

Qty.	Description	Width	Length	
2	(A) Bed Face Panels	21 ¼"	77 5/16	
2	(B) Verticals	16"	85 1/4	
1	(C) Headboard	14 ¼"	43	
1	(D) Top Panel	14 ½"	43	
1	(E) Top Facia	2 ¾"	43"	
1	(F) Bottom Rear Base	6"	43"	
1	(G) Bottom Kick	4"	43"	
2	(H) Header Cleats	1 ½"	14 ½"	
1	(I) Header Stop	1	43	
8	Brackets			
Various	¾" screws			
4	Hardwood Dowels			
18	1 ½" screws			
10	1 ¼" finish nails			
16	2" Screws			
3	3" Screws			
6	Dowels			

## Full/Double

### Overall Cabinet Dimensions

**Mattress Size:** 54" x 75" (12" Max Thickness) 59 1/2"w x 85 1/4"h x 16"d (Projection from wall: 85")

Qty.	Description	Width	Length	
4	(A) Bed Face Panels	14 3/8"	77 5/16	
2	(B) Verticals	16"	85 1/4	
1	(C) Headboard	14 1/4"	58"	
1	(D) Top Panel	14 1/2"	58"	
2	(E) Top Facia	2 3/4"	58"	
1	(F) Bottom Rear Base	6"	58"	
1	(G) Bottom Kick	4"	58"	
2	(H) Header Cleats	1 1/2"	14 1/2"	
1	(I) Header Stop	1	58	
8	Brackets			
Various	3/4" screws			
4	Hardwood Dowels			
18	1 1/2" screws			
10	1 1/4" finish nails			
16	2" Screws			
3	3" screws			
6	Dowels			

# Queen

## Overall Cabinet Dimensions

**Mattress Size:** 60" x 80" (12" Max Thickness) 65 ½"w x 90 ¼"h x 16"d (Projection from wall: 90")

Qty.	Description	Width	Length	
4	(A) Bed Face Panels	15 ⅞"	82 5/16"	
2	(B) Verticals	16"	90 ¼"	
1	(C) Headboard	14 ¼"	64"	
1	(D) Top Panel	14 ½"	64"	
2	(E) Top Facia	2 ¾"	64"	
1	(F) Bottom Rear Base	6"	64"	
1	(G) Bottom Kick	4"	64"	
2	(H) Header Cleats	1 ½"	14 ½"	
1	(I) Header Stop	1	64	
8	Brackets			
Various	¾" screws			
4	Hardwood Dowels			
18	1 ½" screws			
10	1 ¼" finish nails			
16	2" Screws			
3-4	3" Screws			
6	Dowels			

# What we have done for you!

- 4-(A) Bed Face Panels
  - Cut to width and length
  - Edge band edges (Top and left for left pane, top and right on right panel and top on center panels)
  - Broke over edges
  - Sanded with to 220 grit (prep for finish)
- 2-(B) Verticals
  - Cut to width and length
  - Edge band edges (Front edge)
  - Bore the 5 holes on each for mechanism
  - Countersink each hole
  - Bore hole for dowels to locate headboard.
  - Broke over edges
  - Sanded with to 220 grit (prep for finish)
- (C) Headboard
  - Cut to width and length
  - Edge band edges
  - Bore holes for dowels
  - Broke over edges
  - Sanded with to 220 grit (prep for finish)
- (D) Top Panel
  - Cut to width and length
  - Mortise dowel holes
  - Edge band edge
  - Broke over edges
  - Sanded with to 220 grit (prep for finish)
- (E) Top Facia
  - Cut to width and length
  - Mortise dowel holes
  - Edge band edges
  - Broke over edges
  - Sanded with to 220 grit (prep for finish)
- (F) Bottom Rear Base
  - Cut to width and length
  - Edge band edges
  - Broke over edges
  - Sanded with to 220 grit (prep for finish)
- (G) Bottom Kick
  - Cut to width and length
  - Edge band edges
  - Broke over edges
  - Sanded with to 220 grit (prep for finish)
- (H) Header Cleats
  - Cut to width and length
  - Broke over edges
  - Pre-drilled 9 holes
- (I) Header Stop
  - Cut to width and length
  - Broke over edges
  - Pre-drilled and countersunk 5 holes

## Step 2: Build the Header

Using the (D) Top Panel, (E) Top Facia and, 2- (H) Header Cleats assemble the Header.

2-1 Most versions will have holes in the Top Facia and Top Panel to insert dowels. Insert 3 on each side of the Top Panel.

2-2 Attach the Top Facia to the Top Panel with 1 ¼" finish nails (not supplied). Top Facia will overlap the lower side of the Top panel by ½" (see figure 2-1)

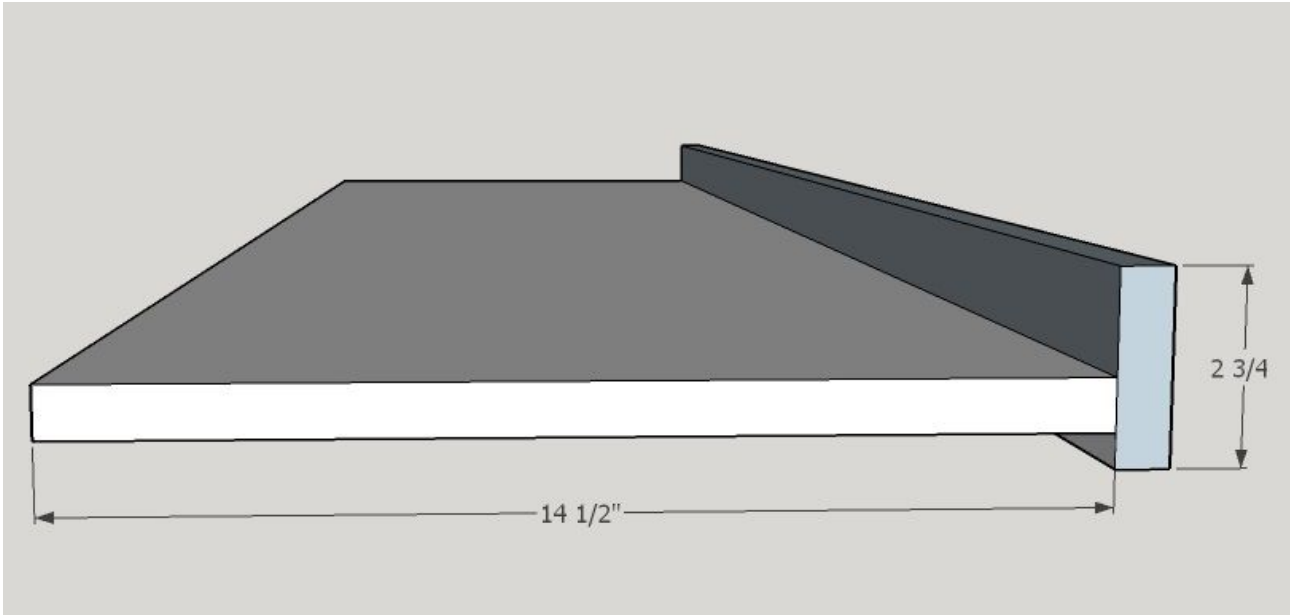
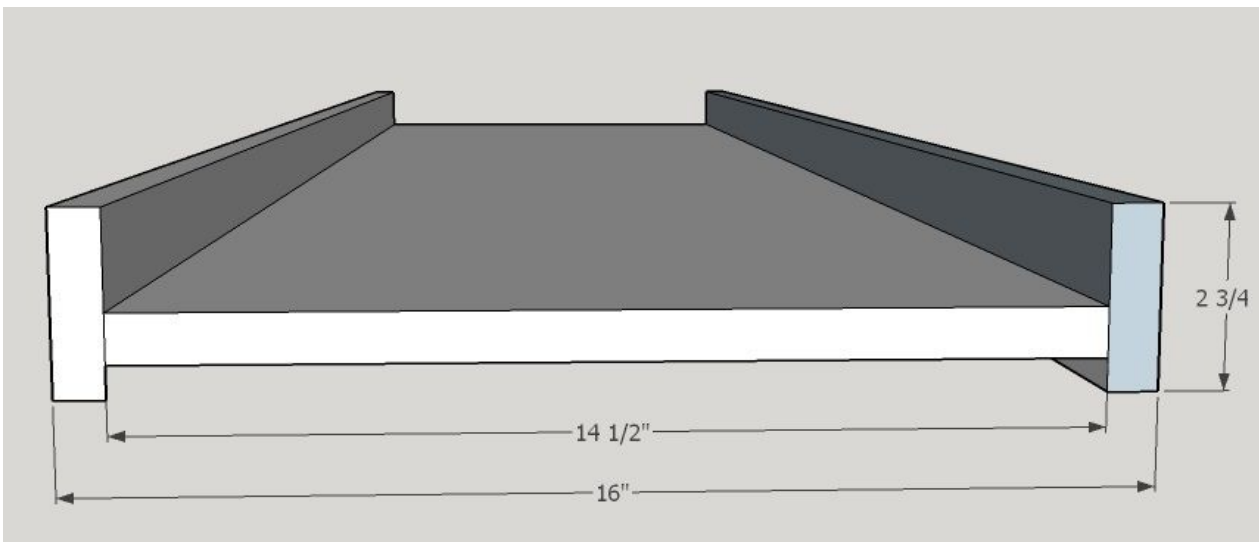

Figure 2-1

2-2 Attach the Back Facia to the top panel. Pre-drill holes using 1/8" bit about every 8-10". Use a countersink so that the screw will be slightly recessed when inserted. Insert 2" screws supplied.





2-3 Attach the Header Cleats with 4- 1 4" screws (supplied) on each end. Flush the cleats with the edge of the Top Facia (see figure 2-2)

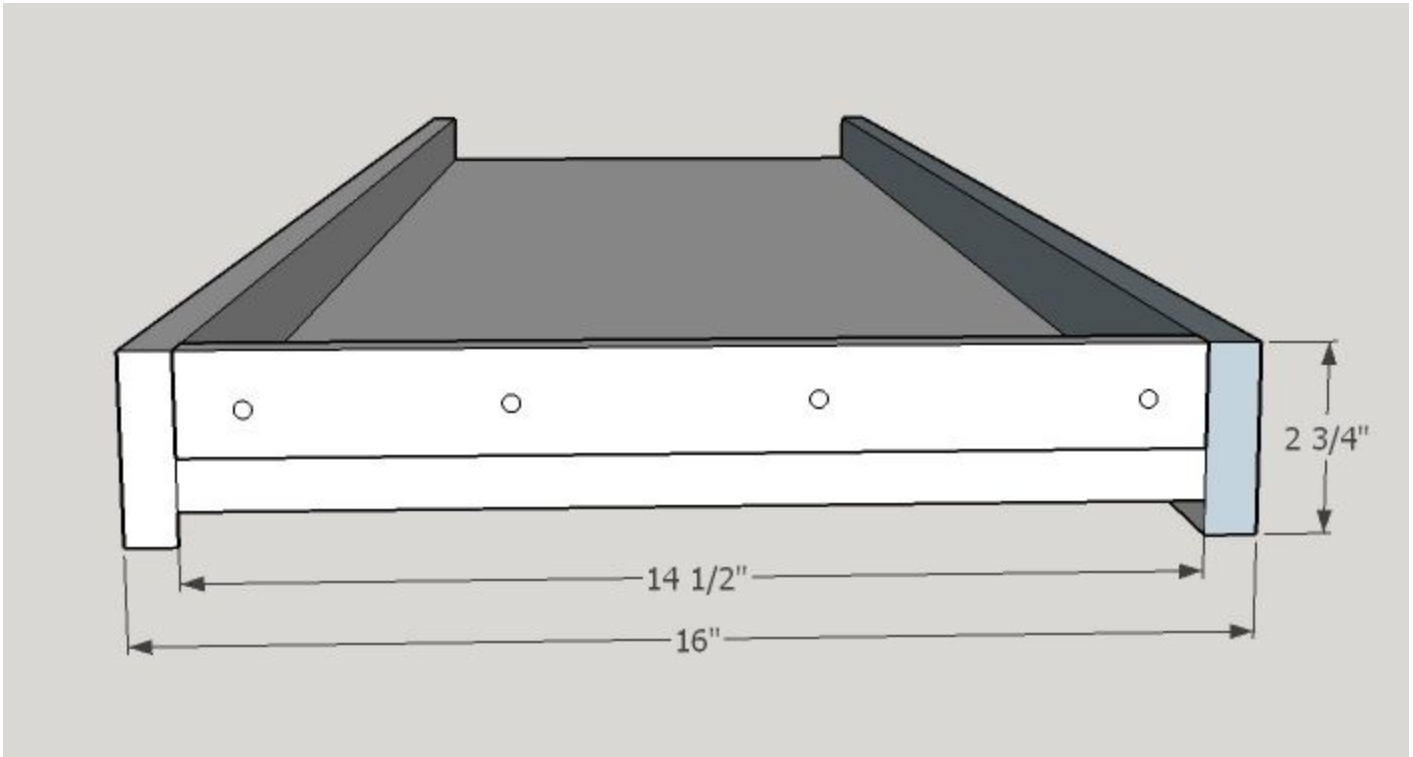
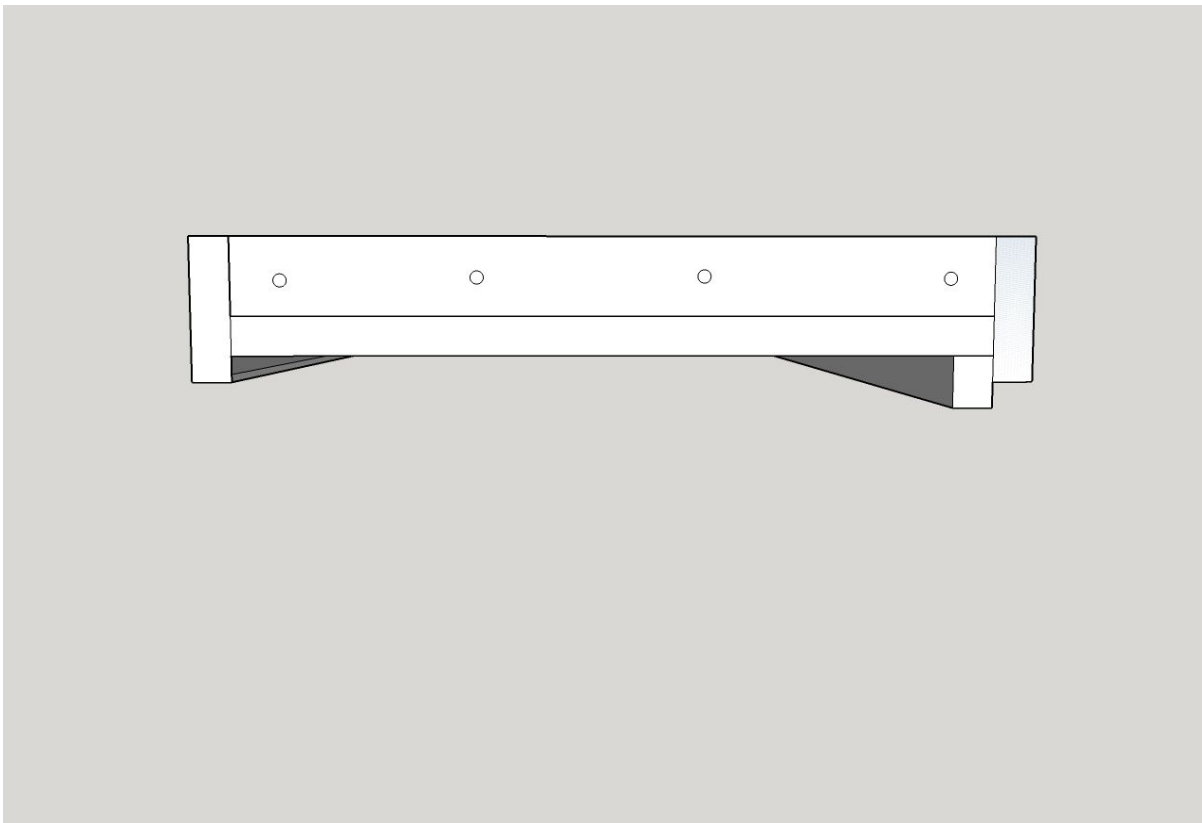

Figure 2-2

2-4 Attach the Header Stop to the underside of the Header toward the front. Attach with 1 1/2" screws.



Your header is now complete!

### Step 3: Finish all wood components

-Finish both sides of all components.

*[Illegible text]*

## Install the Murphy Bed

### Step 4: Install the springs and the Lift Mechanism

4-1: The left and right mechanism hole pattern will line up with the hole pattern on the Side Panel (B). The bolts will be fed through the side that has the counter sinks drilled.

4-2 Hole A will not have a standard nut. It is either a threaded hole or it will use a disk like bolt “Arm Lock Stop”. Get Hole A started.

4-3 Insert the bolt in the other holes and loosely tighten onto the nuts.

4-4 Once all are in place securely tighten using the Allen Wrench provided and a 1/2” wrench.

SPRING APPLICATION CHART		
Please Note: These are recommendations only. Actual number of springs required will depend on the total weight of the bed-face unit including the mattress and all bedding.		
BED SIZE	BED PANEL MATERIAL	
	Plywood Core	Particle Board
Single/Twin	4-5 springs per side	5-6 springs per side
Double/Full	6-7 springs per side	7-8 springs per side
Queen	7-8 springs per side	8-9 springs per side
King	9 springs per side	not recommended
After you have completed installing and checking the operation of your bed, you may find it necessary to add or remove springs to achieve the correct lift effort of between 5 to 10 pounds.		

There are nine locations for springs. If the bed requires an even number of springs, do not use the center hole (#5 from the top). If the bed requires an odd number of springs, start with the center hole (#5 from the top) and work outward in both directions evenly.

Hook the springs so the open ends are facing outward. You may have to gently pry up the tension arm and slide the spring under and snap them into place in the proper hole, matching the same numbered hole from the top of the mechanism back plate. You should have an equal number of springs on each side of the center hole.

Use the same number of springs and the same layout on both the left and right mechanisms.

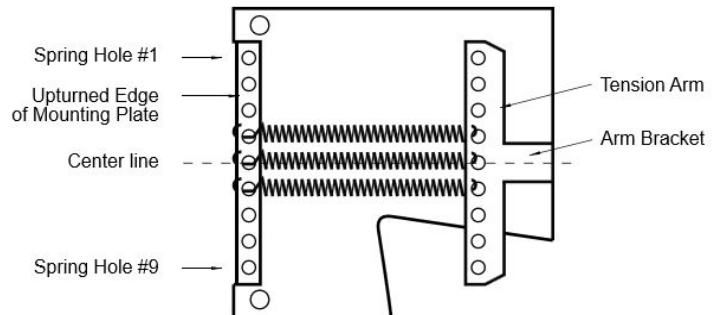

## Step 5: Assemble the Bed Cabinet

The following installation will be done with the bed face down on the floor.

Place the verticals finished edge down and dowel holes toward the inside on a clean floor. You may even lay a soft blanket down to protect the finish from being scratched.

### Headboard installation

5-1: Insert the headboard dowels into the ends of the headboard (two on each side). No need to measure we've taken that step out of you. With the pocket screw holes facing toward the back, insert the headboard dowels into the side of the verticals. Secure with 1 1/2" screws (4 each side).

5-2: Attach header as shown in Drawings 6 & 7. Be sure back edge of the header is flush with back of Side Panels and the top. Attach with 1 1/2" supplied screws.

## Lights

### If you don't have lights skip to step 5-3

L-1. Using the BLUE assembly book, assemble the bed components.

NOTE: STOP ON STEP 7 WHILE BED IS STILL LYING ON FACE.

L-2. Mount the control box to the head side of the metal frame on the inside. Attach with 2- 1 1/2" screws. make sure the arrow is facing up.

L-3. Mount the touch sensor plate on the center of the headboard with one 3/4" screw provided. Find the touch sensor wire on the control box (small thin wire). Put the other 3/4" screw through the eye connector of the touch wire and into the touch sensor plate.

UVOMU [ ^Á [ á^•Á æ Á@Á Á  
à'æ•Á |æ ÉÁ@Á @ |áÁ^Áææ@áÁ [ Á@Á  
àæ\ [ ] É^) c'Á Á@Á@æà[ æáÉÁ

L-4. Run the extension cord up the groove in the vertical, making sure the female end is at the top of the vertical and there is about 3" of slack at the top. Attach the other wires: from the box to the white cord, and from the box to the wall.

L-5. Plug the white cord into the first light. Plug the two lights together

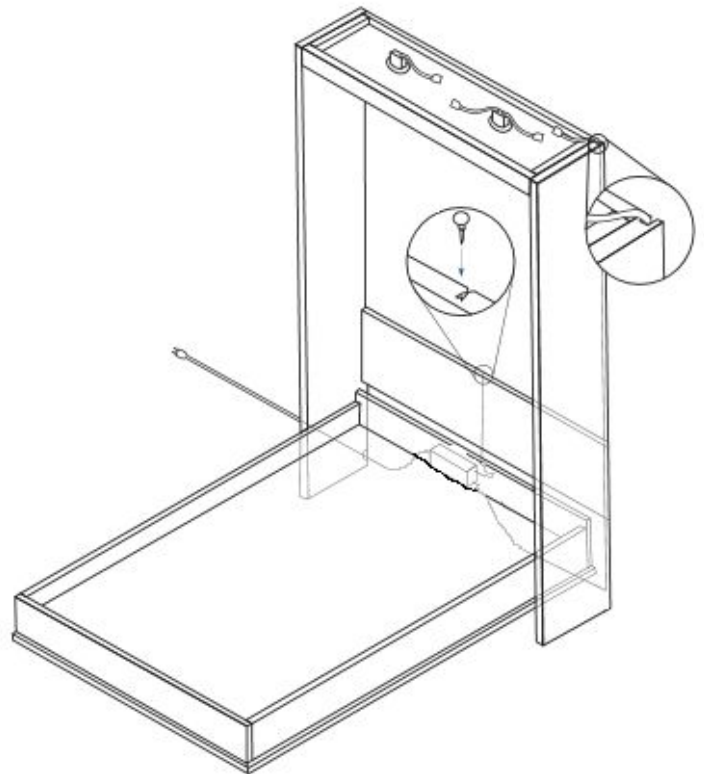

5-3: Stand the bed up in place. Use Angle Brackets to assemble Bottom Rear Base and Bottom Kick in position shown in Drawings 6 & 7. Use two Angle Brackets on each end. Attaching using supplied 3/4" screws.

NOTE: The Bottom Rear base can be moved closer to the front if there is a cutout for base molding on the back of the verticals.

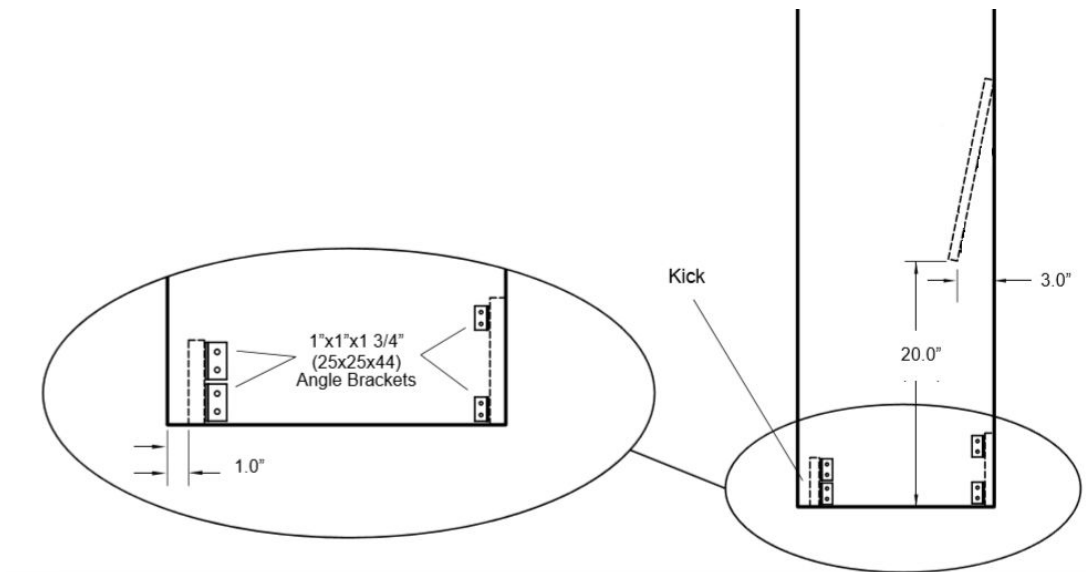
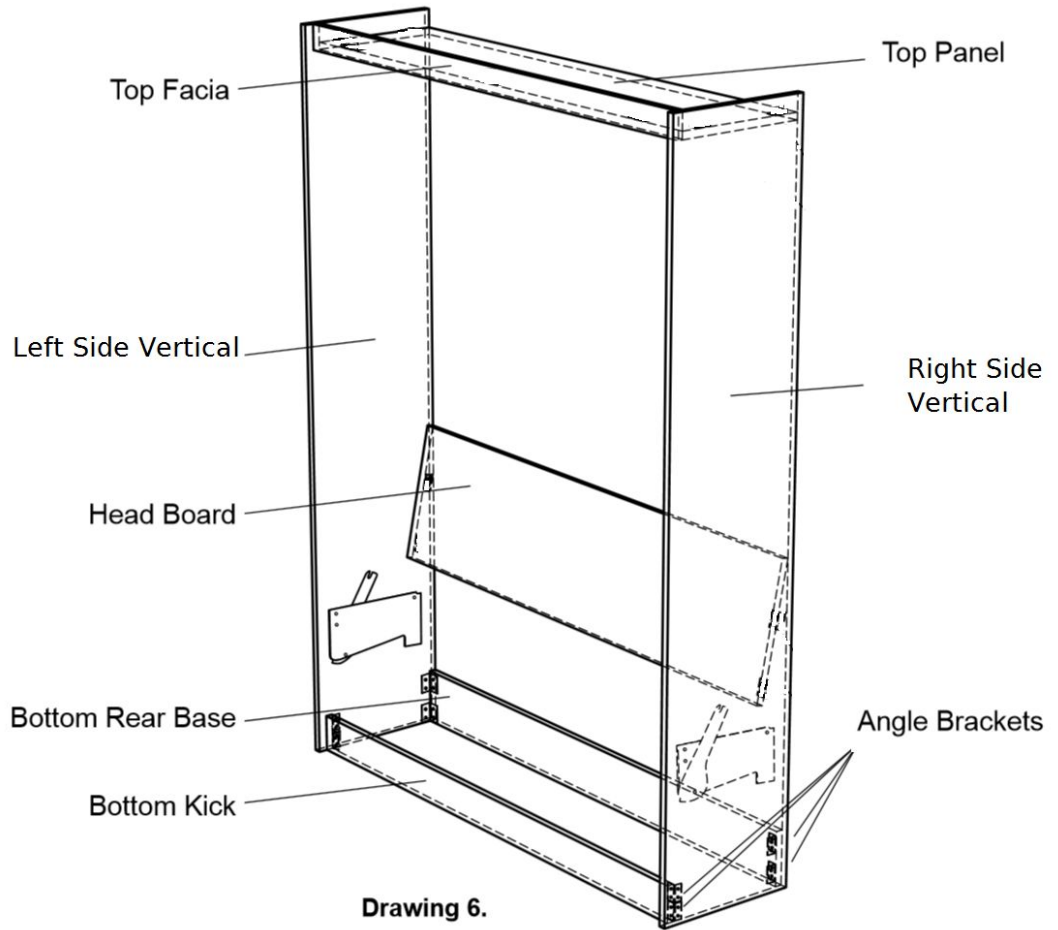

Drawing 7

Brackets may be different than used in the drawing

## Step 6: Attach Bed Cabinet Securely to Wall

*(Note: For your header I changed the bracket shown to mount to wall to a solid strip (see step 6-2))*

We cut out for your base molding so you don't have to remove base molding off the wall. If our cutout was not large enough more may need to be done. Use a jig saw to perform this task.

### 6-1: Find Studs

Prior to placing cabinet against the wall, locate 3 studs or other wall frame members at the level of the Top Panel (top of bed). Alert: The cabinet must be secured to studs or other wall structural members using L-Brackets. If the wall is not a wood stud wall, use metal stud screws, toggle bolts or concrete expansion bolts if necessary.

### 6-2: Attach to wall

Now that the cabinet is square and plumb, **pre-drill hole in that backboard of the header at the stud location and 3" screws. Repeat this for two other stud locations.** (see Drawing 9. but instead of brackets you'll drill through the back board on the header).

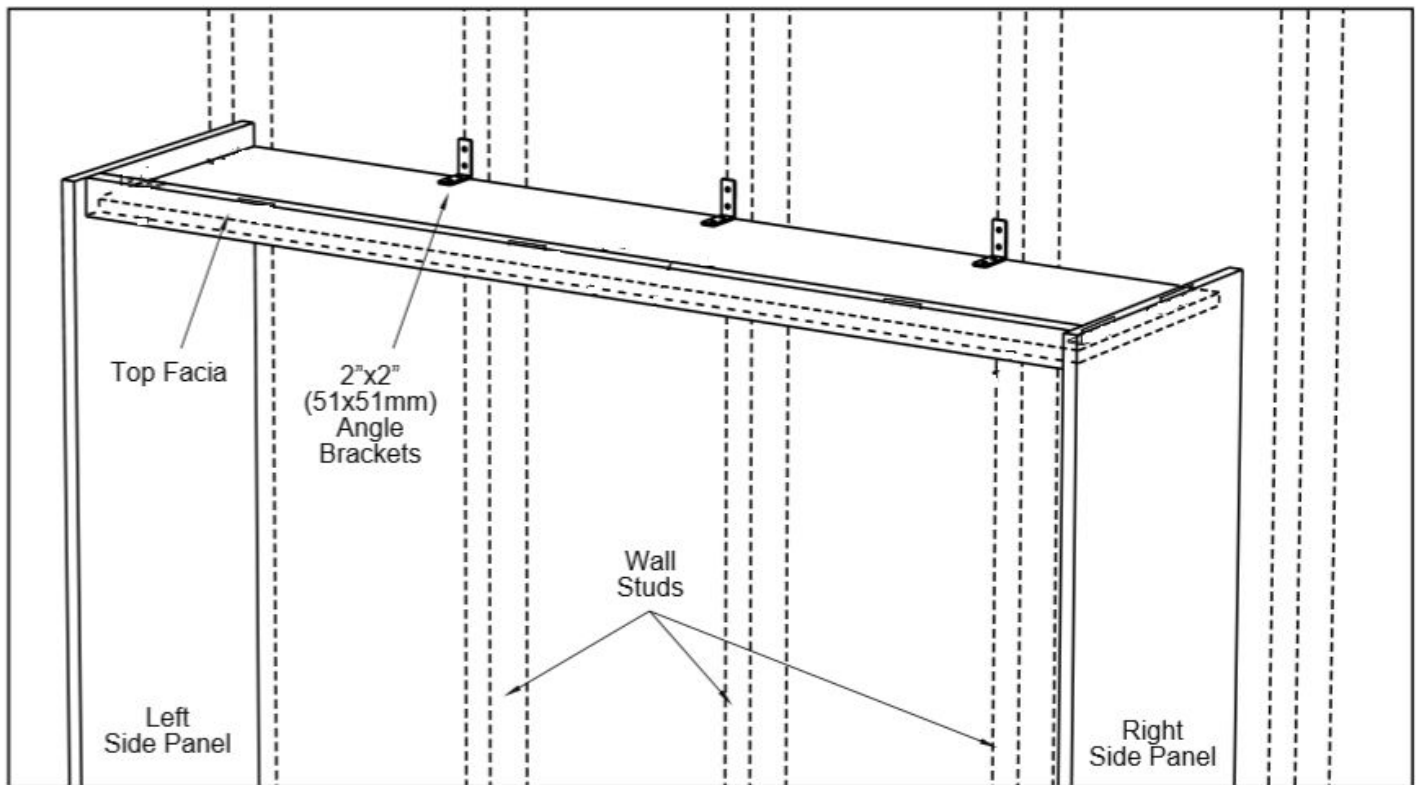

Note: change in header design. There is now a backboard on there header instead of the brackets.

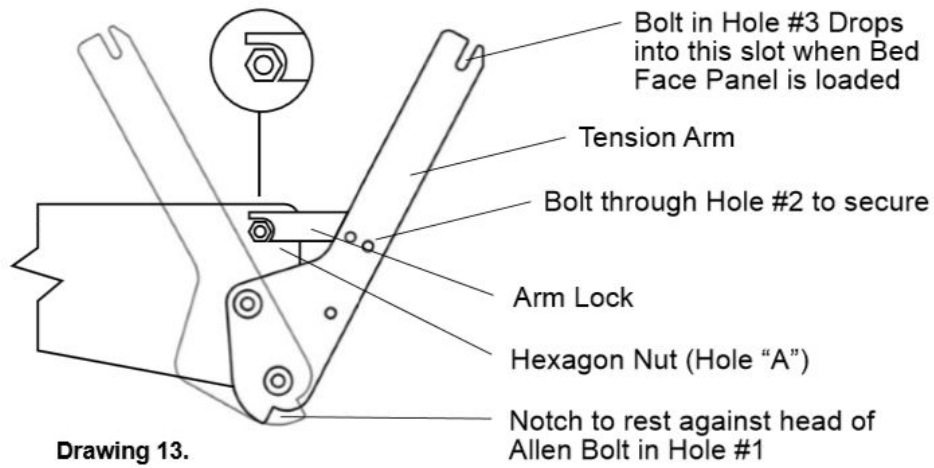

Drawing 13.

Holding one foot against the bottom front edge of the side panel and using the 13" (330mm) PVC tube, lever the tension arm out until you can set the arm lock to the hex nut at the hole A (see drawing 13.). This is the hex nut at the top front corner of the mechanism.

Vā KŌÁ[ ~ Á^ó@ÁE{ Š[ &+Ű} Á] Á -ó@Á[ |óŰ+Ű'ŰÁ[ ~ Á ~ ||ó@Á^} •Ű} ÁE{ ÁæŰ ŠŰ Ű|ÁŰ/Ű Ű Á |æŰ ÉŰ[ Á }[ Á ~ óÁ[ ~ |ÁŰ \*Ű'•ÁæŰ ŠŰ/ŰÁŰ Á @ŰÁ ~ ||Ű \*ŠŰæŰ ÉŰ

Óæ Ű} KŌÁ[ ••Ű/Ű@Ű ÁŰ@|| /Ű/Ű •Ű ŰóŰ ŠŰ@Ű^ŰŰ \*Ű -ó@Ű ^&Ű Ű { ŠŰ áŰ ŰŰŰ \*Ű -ó@Ű áŰæŰ Á Ű /ÉŰŰÁ PUVÁ^æŰ ŰŰ @ áŰ@Ű} •Ű} ŠŰ{ Á @} Á[ ~ ŠŰ^ŠŰ Ű \*Ű@Ű^ŰŰ \*Ű | / &Ű'ŰÉŰ

## Step 8: Install the Bed Face Panel Unit

**Frame laid out for assembly in the Vertical orientation.**

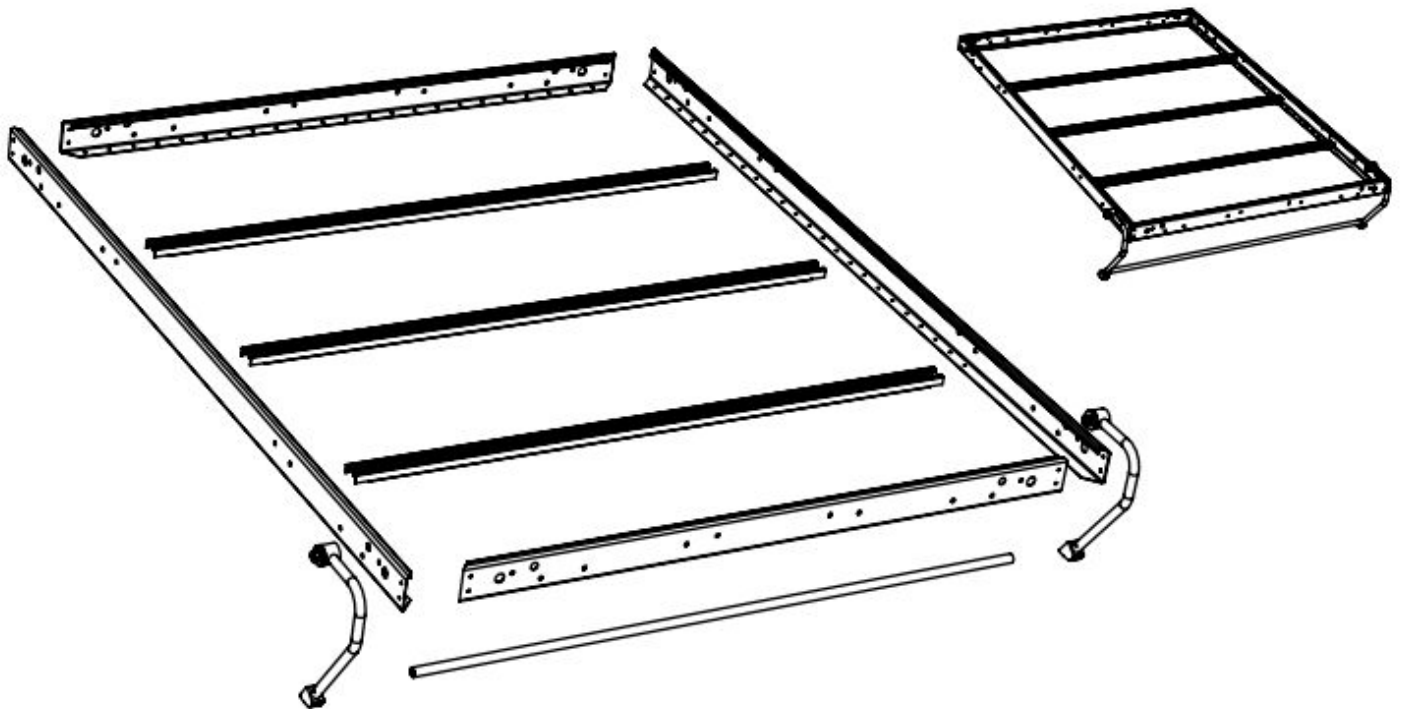

Frame flush with end of Face Panels

Bed Face Panels

Head of Bed

Stiffener

Stiffener

Stiffener

Attach Nylon Web Strap Here

Foot of Bed

1.0"  
(25)

1.0"  
(25)

Bed Face Panel

Leg Stop

Side View (do not install legs at this time, it is shown for reference only)

Floor

Drawing 10.  
Plan View

Drawing 12.

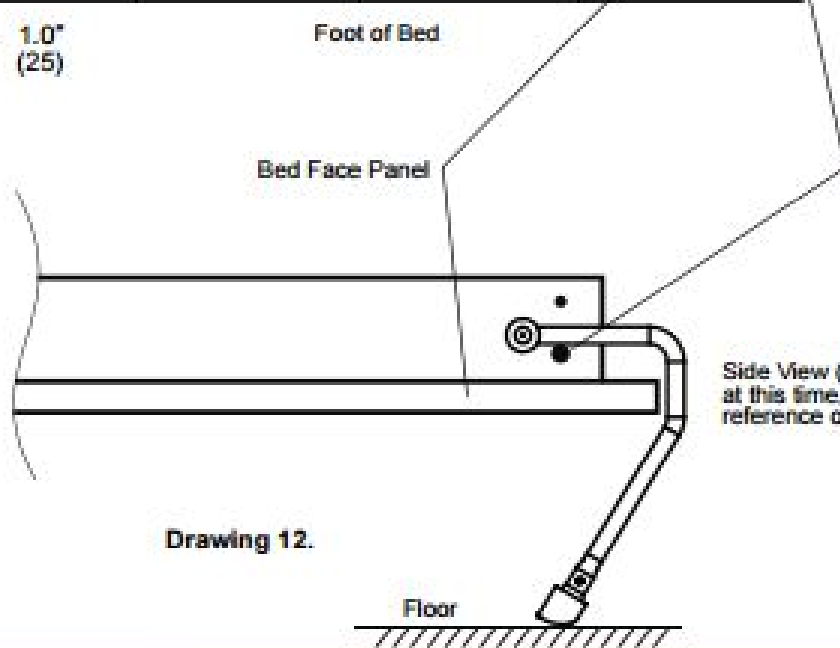
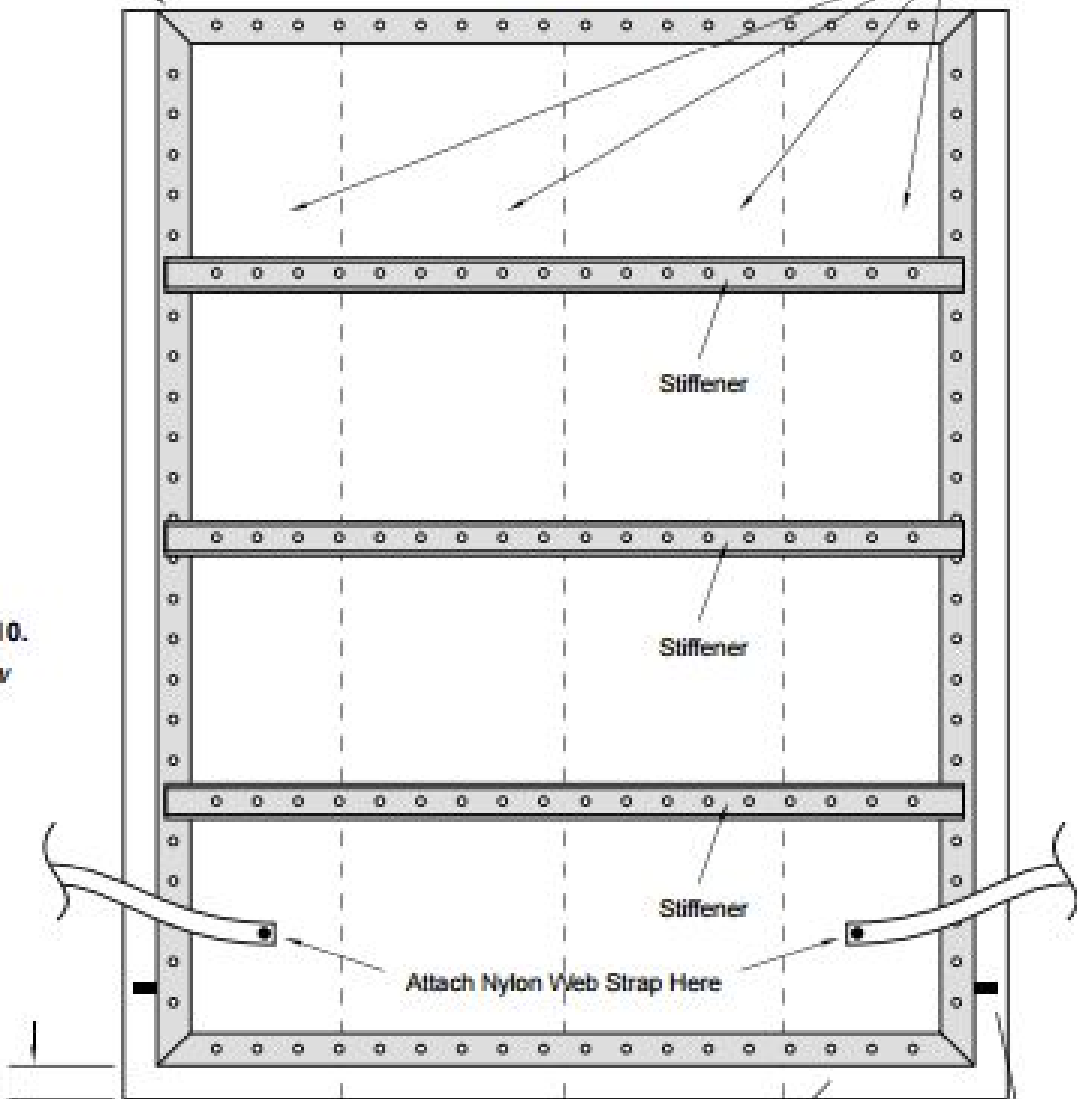

7-1 Lay the Bed Face Panels down on a non-scratch surface such as a carpet or blanket. Make sure they the better side is face down and banded edges facing out and toward the foot of the bed.

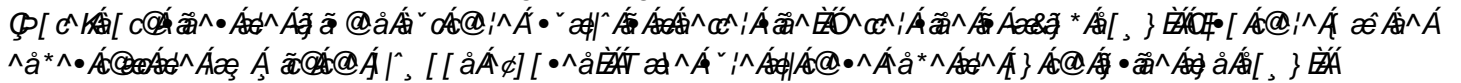

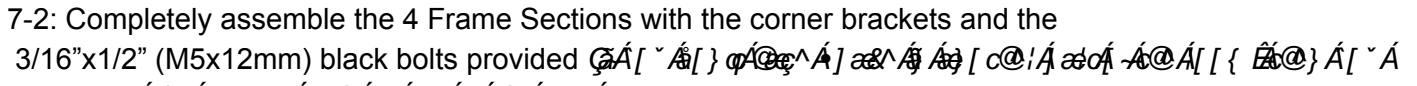
7-2: Completely assemble the 4 Frame Sections with the corner brackets and the 3/16"x1/2" (M5x12mm) black bolts provided  Refer to Drawing 12 to properly place the leg stops at outer right and left bottom holes at the foot of the bed frame.

7-3: Position the bed frame on the bed face panels. With the Head Frame section flush with the head end of the Bed Face Panels. Refer to Drawing 10. Carefully attach the Bed Frame so it is centered on the Bed Face Panels; you will have approximately 15/16" (24mm) space from the bed frame to the panel edges right and left and at the bed foot.

Note: It is very important to have the Bed Frame centered on the Bed Face Panels. Any error will be noticed in the vertical sight lines when the bed is closed.

7-4: Three steel stiffeners are provided for all beds (5 for King). These notched stiffeners should be located and attached to divide the Bed Face length into four equal sections. Use caution not to damage raised panels by putting screws in recessed areas. Note: King Beds have 5 stiffeners (see diagram on pg. 6 for placement).

7-5: Attach the Nylon Web Strap approximately 18" (460mm) down from the foot of the bed and 6" (150mm) in from the sides, for tucking in sheets. The Straps help secure the mattress in the vertical position (see drawing above

7-6: From hardware card 2, insert a Allen Head Bolts through Hole #1 (6 3/4" from end of side frame) on both left and right side frames (see Drawing 14).

7-7 Also Inserted two 5/16" (M8x20mm) Hex Head Bolts from the outside of the frame through Hole #3. We have left these loose.

7-8 Stand the Bed Face Panel in vertical position between the tension arms, lift evenly until the bolt in Hole #3 drops in the slotted end of each tension arm. Gently tilt the bed face toward you until the Allen Bolts in Hole #1 are completely seated in the bottom notch of the tension arms. Insert the remaining 5/16" (8mm) Hex Head Bolts through tension arms into Holes #2 and fasten with 5/16" (8mm) Nylock Nuts; securely tighten these and the nuts on Hole #3.



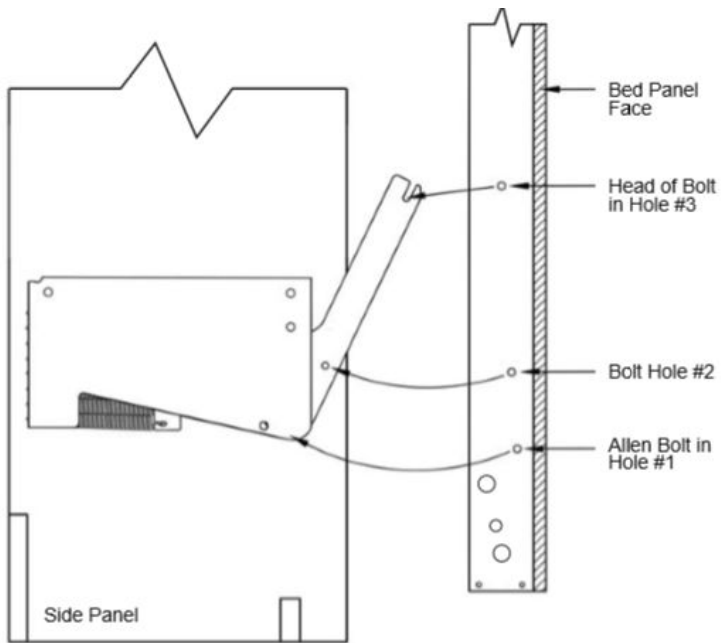

**Drawing 14.**

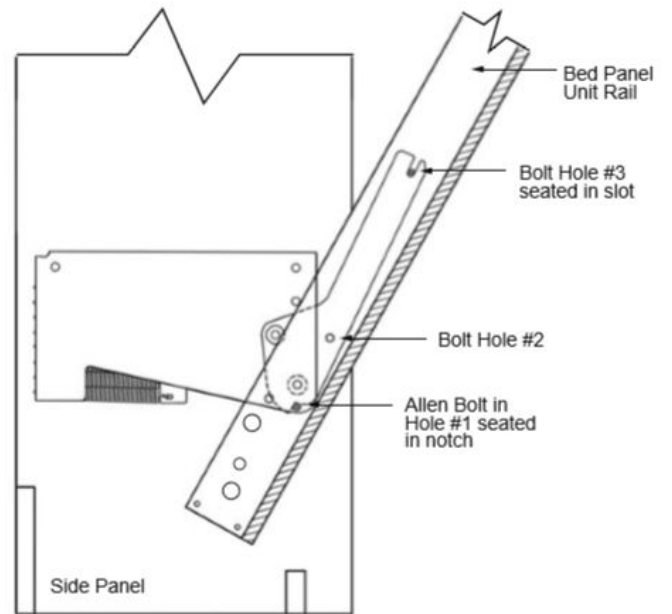

**Drawing 15.**

7-9 When all bolts are securely tightened, you may tilt the panel outward to approximately 45 degrees to release the arm locks. You will hear a click as they disengage.

**Caution:**

Hold the Face Panel securely, Do Not let it slam shut. Balance is not achieved until the mattress is loaded in the bed.

Leveling of the bed cabinet is essential. Check the level both side to side and front to back. Proper leveling will facilitate proper closure and exact sight lines of the fit of the Face Panel to the Cabinet.

## Step 8: Install Handle = Legs - Mechanism Covers - Mattress

8-1 Position and secure handles for ease of operation. Measure down approximately 36" (914mm) from the panel top to the top of the handles.

8-2 Install legs with the washers on the inside of the Rails and the Nylon washer on the outside. Tighten nut to have a small amount of friction when leg assembly is rotated from the up to down position.

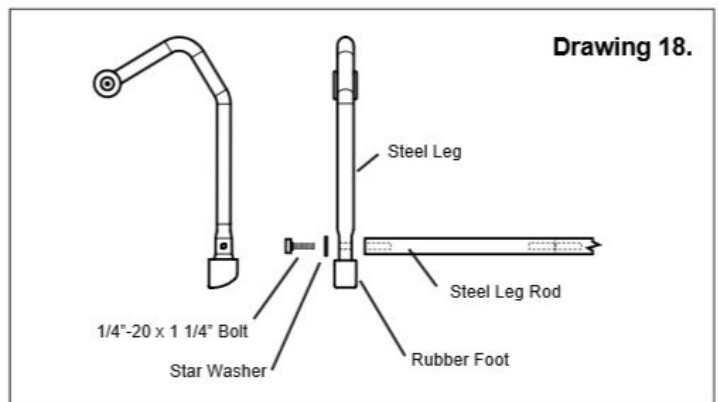
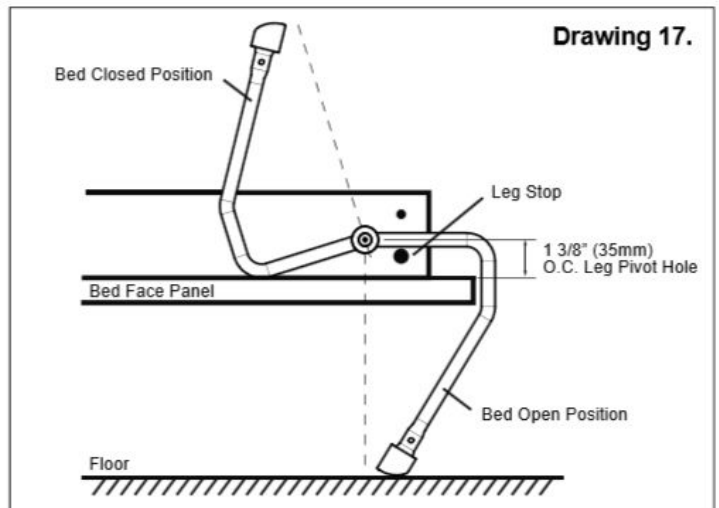
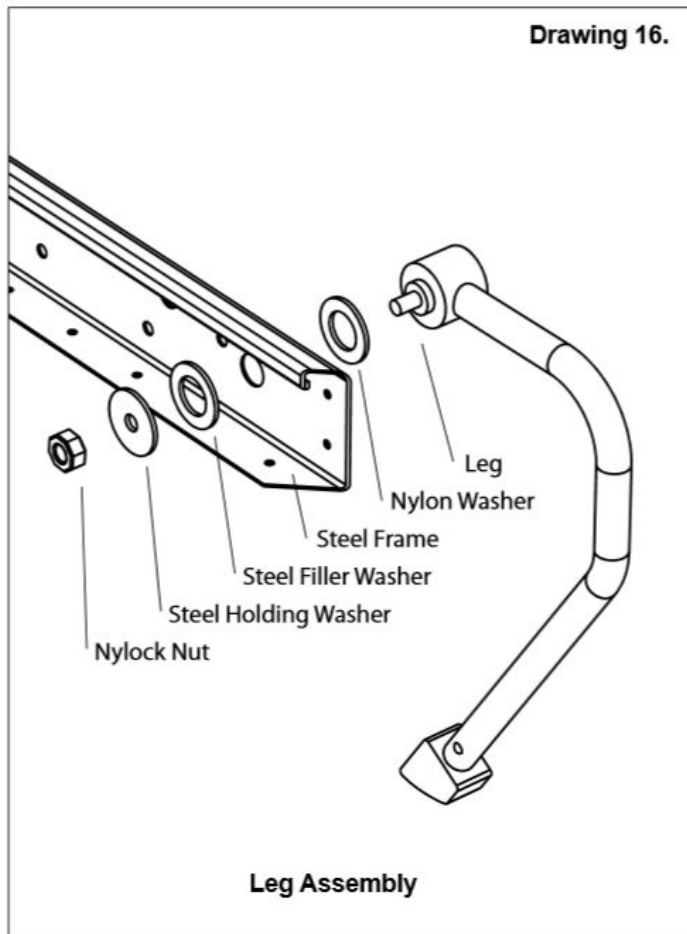

8-3 Install leg connector rod between legs and secure with 1/4"x1 1/4" (M4x32mm) Hex head bolts and star washers. Be sure they are securely tightened so not to become loose.

8-4 Install the mattress and secure with previously installed Nylon Straps.

8-5 Snap the powder coated steel mechanism covers in place - secure with #8x1 1/4" (M4x32mm) black wood screws through the standoff on the backer plate

# Complete Bed Assembly

Follow up to Initial Assembly

Check that the Bed Cabinet is level and square so the Bed Face has equal clearance of the Cabinet on both sides, top to bottom. If the Cabinet is leaning to one side, nudge it at the floor level. If the top is uneven, place shims under the Side Panels. If bed is too heavy to operate easily or slams shut, remove the Bed Face Panel and add or subtract springs. At this time, you may decide to use one more or less spring(s) on the left or right side Lift Mechanism.

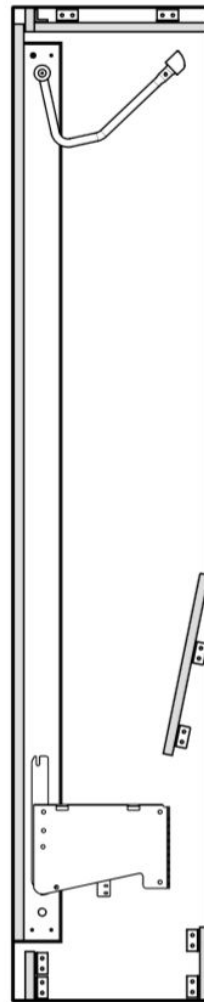
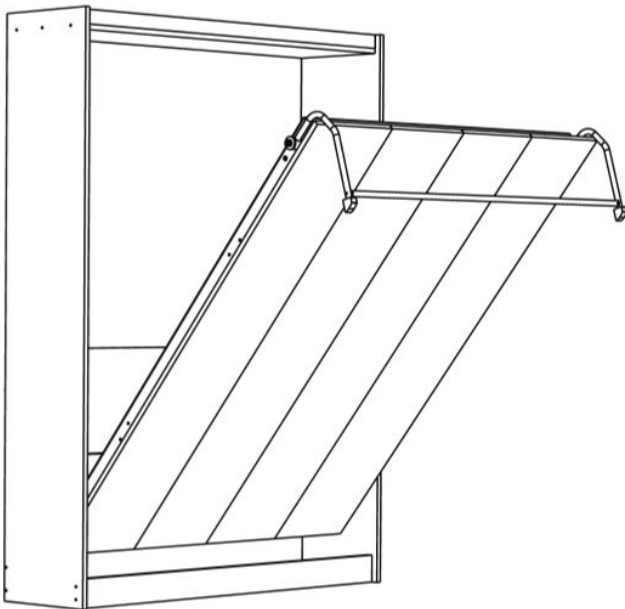

Right Side  
Looking through Side Panel.