

# DIY Murphy Bed

(Horizontal Pre-Cut Version Lights)



It's like having your own shop!

**Assembly Instructions**

**Questions call 501.753.9699**

# Table of Contents

Step 1: Check Your Components

Hardware

Single/Twin

Full/Double

Queen

What we have done for you!

Step 2: Build the Header

Step 3: Finish all wood components

Step 4: Install the springs on the Lift Mechanism

Step 5: Assemble the Bed Cabinet

Step 6: Attach Bed Cabinet Securely to Wall

Step 8: Install the Bed Face Panel Unit

Lights

Step 8: Install Handle = Legs - Mechanism Covers - Mattress

Complete Bed Assembly

## Step 1: Check Your Components

Thank you for your purchase of this DIY Murphy bed. We try to make this projects as easy as possible for you. Take a minute and check your contents.

### Hardware

Qty.	Frame Carton Items	Comments	✓
2	Frame End Sections	Identical Head & Foot	<input type="checkbox"/>
2	Frame Side Sections	Identical, Right or Left	<input type="checkbox"/>
3(5)	Stiffeners - Bed Face (King Size)	Space evenly between Frame Sides	<input type="checkbox"/>
2	Fold-away Legs	One Left - One Right	<input type="checkbox"/>
1	Leg Connector Rod	Stabilizes and Eases Leg Operation	<input type="checkbox"/>
<b>Hardware Card #3</b>			
14	Bolt 10-24x1/2" (M6x12mm) Black	Bolt Frame corners	<input type="checkbox"/>
2	Bolt 10-24x1 1/4" (M6 x 32mm) Black	Bolt Leg Stop Foot corners	<input type="checkbox"/>
16	Nut 10-24 (M6) Black Nylock	Use with #1214 & #1213	<input type="checkbox"/>
4	Angle 1"x1"x1 3/4" (25x25x44mm) Black	Use inside Frame corners	<input type="checkbox"/>
2	1/2"x3/4" (13x19mm) Round Black Cylinder	Use with #1213 as Leg Stop	<input type="checkbox"/>
<b>Hardware Card #4</b>			
2	1 1/2"x5/16" (T1.5x40mm) Black Washer	Secure Leg inside Frame	<input type="checkbox"/>
2	1 1/2"x.765" (T2.5x40mm) Black Washer	Secure Leg inside Frame	<input type="checkbox"/>
2	1 1/2"x.765" (T2.5x40mm) Black Nylon Washer	Between Leg & outside of Frame	<input type="checkbox"/>
2	Nut 5/16" (M8) Black Nylock	Secure Leg inside Frame	<input type="checkbox"/>
2	Bolt 1/4"-20 Black Hex Head	Attach Leg to Leg Rod	<input type="checkbox"/>
2	Star Washer for #1210	Attach Leg to Leg Rod	<input type="checkbox"/>
<b>Hardware Card #5</b>			
1	Nylon Web Strap with Buckle	Secure Mattress to Bed Frame	<input type="checkbox"/>
2	3/4"x1/4" (T1.5x25mm) Washer	Secure Nylon Web Strap to Bed Face Panel under Mattress	<input type="checkbox"/>
2	#8x5/8" (M4x15mm) Wood Screw	Secure Nylon Web Strap	<input type="checkbox"/>
<b>Hardware Card #7 - King size includes 2 bags</b>			
110	#8x5/8" (M4x15mm) Wood Screw	Attach Steel Bed Frame to Bed Face	<input type="checkbox"/>

Qty.	Mechanism Carton Items	Comments	
1	Lift Mechanism - Right Side	Attach to Right Side Panel	<input type="checkbox"/>
1	Lift Mechanism - Left Side	Attach to Left Side Panel	<input type="checkbox"/>
2	#1 Bags containing 9 Springs each	Install correct number in each Mechanism	<input type="checkbox"/>
1	13" Plastic Pipe	Used to set the Lift Mechanisms	<input type="checkbox"/>
<b>Hardware Card #2</b>			
10	Machine Screw 5/16-18 x 1 1/4"	To attach Lift Mechanisms to Side Panels	<input type="checkbox"/>
4	Hex Head Bolt 5/16-18 x 1"	Attach Mechanism to Frame Side section	<input type="checkbox"/>
2	Allen Head Bolt 5/16-18 x 1"	Position Mechanism Arm on Frame Side section	<input type="checkbox"/>
16	Hex Head Nylock Nut	Secure Bolts and Screws	<input type="checkbox"/>
1	Allen Wrench 5/16"	For Allen Head bolts	<input type="checkbox"/>

# Single/Twin Horizontal

## Overall Cabinet Dimensions

**Mattress Size:** 39" x 75" (12" Max Thickness) 80"w x 49 3/4"h x 16"d (Projection from wall: 49")

Qty.	Description	Width	Length	<input checked="" type="checkbox"/>
4	(A) Bed Face Panels	19 1/2"	41 3/4"	
2	(B) Side Panels	16"	49"	
1	(C) Top Panel	16"	80"	
1	(D) Top Facia	2"	78 1/2"	
1	(E) Top Facia Stiffener	3"	78 1/2"	
1	(F-1) Top Rear Stiffener	4"	78 1/2"	
1	(F-2) Bottom Rear Stiffener	4"	78 1/2"	
1	(G) Kick & Kick Stiffener ( 1 1/2" thick)	4"	78 1/2"	
1	(H) Head Board	14 1/2"	78 1/2"	
1	(I) Head board Stiffener	4"	78 1/2"	
3	(J) Panel Connectors	3"	37"	
2	(K) Top Cleats	1"	13 13/16"	
2	Center Cleats (for light panel	1	13 13/16"	
1	Light Panel	13 5/8"	78 3/8"	
8	1 1/2" screws for Light Cleats			
	Light Kit			
28	1 1/2" Pocket screws (Top Build)			
40	1 1/4" finish nails (Top Build)(Headboard Build)			
8	Brackets (with 16 - 3/4" screws)			
16	1 1/2" Pocket Screws (Top Install)			
4	Hardwood Dowels (Headboard Installation)			
8	1 1/2" Pocket Screws (Headboard Install)			

## Full/Double Horizontal

### Overall Cabinet Dimensions

**Mattress Size:** 54" x 75" (12" Max Thickness) 80"w x 64 3/4"h x 16"d (Projection from wall: 64")

Qty.	Description	Width	Length	<input checked="" type="checkbox"/>
4	(A) Bed Face Panels	19 1/2"	56 3/4"	
2	(B) Side Panels	16"	64"	
1	(C) Top Panel	16"	80"	
1	(D) Top Facia	2"	78 1/2"	
1	(E) Top Facia Stiffener	3"	78 1/2"	
1	(F-1) Top Rear Stiffener	4"	78 1/2"	
1	(F-2) Bottom Rear Stiffener	4"	78 1/2"	
1	(G) Kick & Kick Stiffener ( 1 1/2" thick)	4"	78 1/2"	
1	(H) Head Board	14 1/2"	78 1/2"	
1	(I) Head board Stiffener	4"	78 1/2"	
3	(J) Panel Connectors	3"	52"	
2	(K) Top Cleats	1"	13 13/16"	
2	Center Cleats (for light panel	1"	13 13/16"	
1	Light Panel	13 3/8"	78 3/8"	
8	1 1/2" screws for Light Cleats			
	Light Kit			
28	1 1/2" Pocket screws (Top Build)			
40	1 1/4" finish nails (Top Build)(Headboard Build)			
8	Brackets (with 16 - 3/4" screws)			
16	1 1/2" Pocket Screws (Top Install)			
4	Hardwood Dowels (Headboard Installation)			
8	1 1/2" Pocket Screws (Headboard Install)			

## Queen Horizontal

### Overall Cabinet Dimensions

**Mattress Size:** 60" x 80" (12" Max Thickness) 85"w x 70 3/4"h x 16"d (Projection from wall: 70")

Qty.	Description	Width	Length	<input checked="" type="checkbox"/>
4	(A) Bed Face Panels	20 3/4"	62 3/4"	
2	(B) Side Panels	16"	70"	
1	(C) Top Panel	16"	85"	
1	(D) Top Facia	2"	83 1/2"	
1	(E) Top Facia Stiffener	3"	83 1/2"	
1	(F-1) Top Rear Stiffener	4"	83 1/2"	
1	(F-2) Bottom Rear Stiffener	4"	83 1/2"	
1	(G) Kick & Kick Stiffener ( 1 1/2" thick)	4"	83 1/2"	
1	(H) Head Board	14 1/2"	83 1/2"	
1	(I) Head board Stiffener	4"	83 1/2"	
3	(J) Panel Connectors	3"	58"	
2	(K) Top Cleats	1"	13 13/16"	
2	Center Cleats (for light panel	1	13 13/16"	
1	Light Panel	13 3/8"	83 3/8"	
8	1 1/2" screws for Light Cleats			
	Light Kit			
28	1 1/2" Pocket screws (Top Build)			
40	1 1/4" finish nails (Top Build)(Headboard Build)			
8	Brackets (with 16 - 3/4" screws)			
16	1 1/2" Pocket Screws (Top Install)			
4	Hardwood Dowels (Headboard Installation)			
8	1 1/2" Pocket Screws (Headboard Install)			

## What should be done for you!

- (C) Top Panel
  - Cut to width and length
  - 3 Edge band edges (front and 2 sides)
  - Broke over edges
  - Sanded with to 220 grit (prep for finish)
- (D) Top Facia (?? x 2")
  - Cut to width and length
  - Edge band 1 edge
  - Broke over edges
  - Sanded with to 220 grit (prep for finish)
- (E) Top Facia Stiffener (?? x 3")
  - Cut to width and length
  - Edge band 2 edge
  - Pockets added to the back.
    - 1 each end and centered on the 3" edge
  - Broke over edges
  - Sanded with to 220 grit (prep for finish)
- (F-1) Top Rear Stiffener (?? x 4)
  - Cut to width and length
  - Edge band edges
  - Pockets along the top (opposite the banded edge)
    - Starting about 2 1/2" from edge and every 7-8 inches.
  - Pockets added to the back.
    - 1 each end and centered on the 4" edge
  - Broke over edges
  - Sanded with to 220 grit (prep for finish)
  - Pocket two pockets in each end for the installation step.

## What you may have to do!

- (K) Top Cleats (see step 1)
  - Cut to width and length (2 - 13 13/16" x 1")
  - Holes drilled and countersink through the 1" direction at 1" and 5" from each end
  - Sanded and edges broke.

## Step 1: Check and Prep Pieces

1-1 Make sure the pockets are in the (D) Top Facia

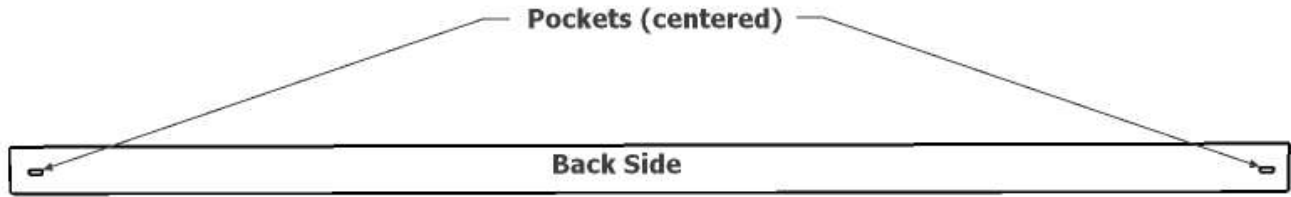

1-2 Make sure pockets are in the (F-1) Top Rear Stiffener.

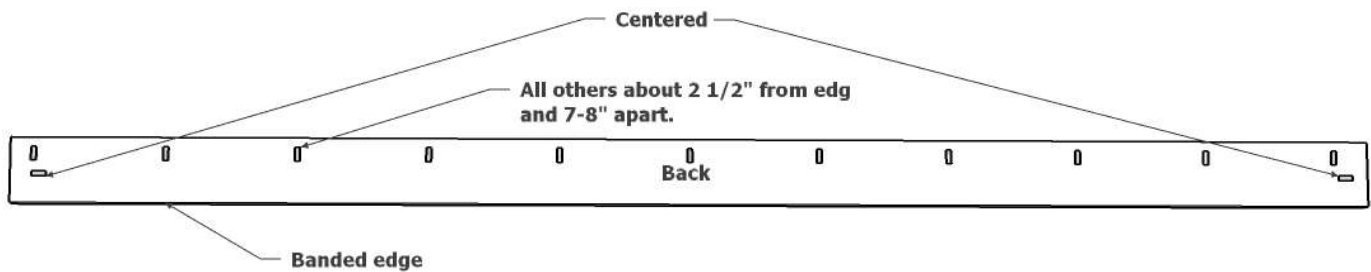

1-3 Build the cleats.

### No Lights:

2 - 13 13/16" x 1". Holes will be drilled through the 1' direction at 1" and 5" from each edge

**Modifications for lights:** for one of the cleats (normally the left side), it will be 1" shorter (12 13/16" x 1) Same drill pattern (1" and 5")

3 - 13 13/16" x 1"

1 - 12 13/16" x 1" (left side)

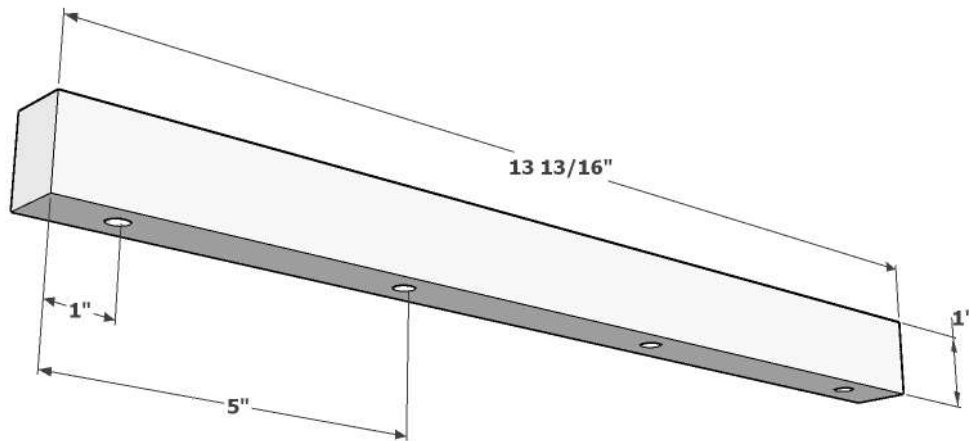



## Step 2: Build the Header

Using the (C) Top Panel, (D) Top Facia, (E) Top Facia Stiffener, (F-1) Top Rear Stiffener, (K) Top Cleats assemble the Header.

2-1 Attach the Top Facia to the Top Panel with glue and 1 ¼" Brad nails. Make sure the banded edge of the (D) Top Facia is down and the Top Fascia is attached to the banded edge of the Top Panel. Flush with the front and ¾" off each side. Divide any slight variance in the ¾" offset evenly on each side. **Change using 1 ½" Verticals: Measurements should be 1 ½" instead of ¾"**. Tip: use small hand clamps to hold the Top Facia in place while securing it with nails. (see figure 2-1)

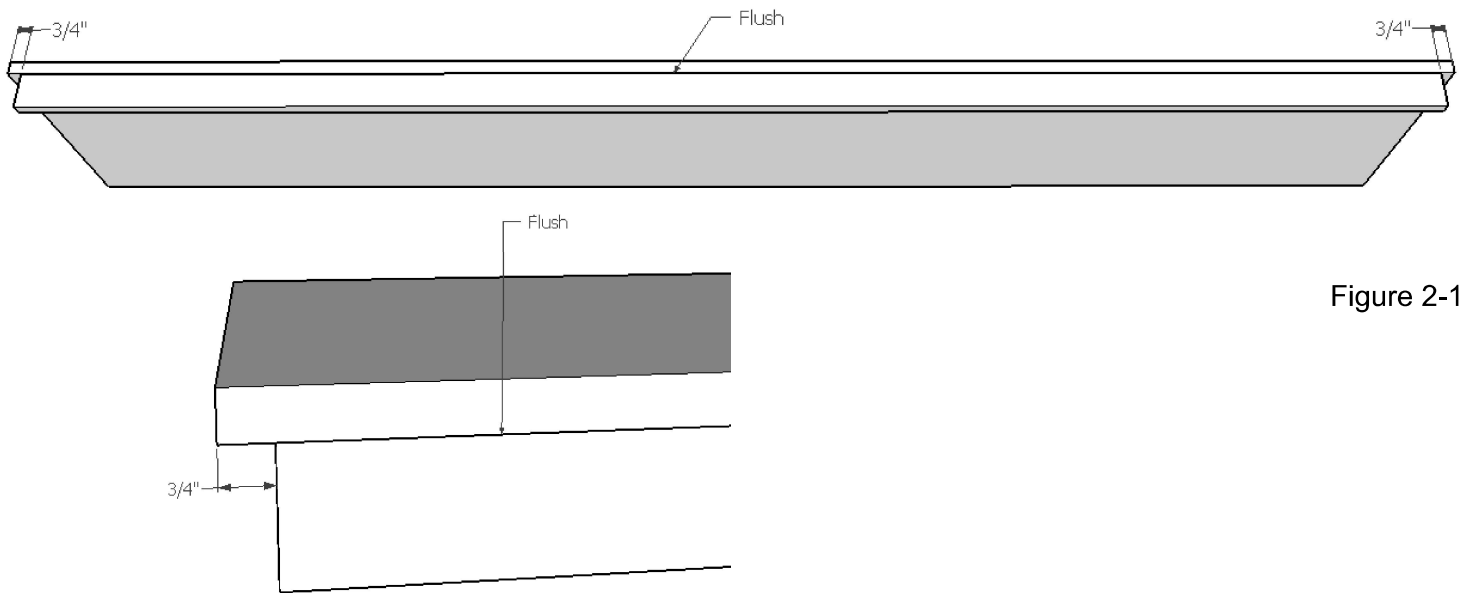

Figure 2-1

2-2 Attach the Top Facia Stiffener to the Top Facia using glue and 1 ¼" Brad nails. Nail from the inside. Make sure the banded edge is out (up in this orientation). Note: make sure the pockets are facing toward the back. This will be the same ¾" off the sides as in the previous step. **Change using 1 ½" Verticals: Measurements should be 1 ½" instead of ¾"**. Glue both edges that touch both the Top Panel and Top Facia for added strength.

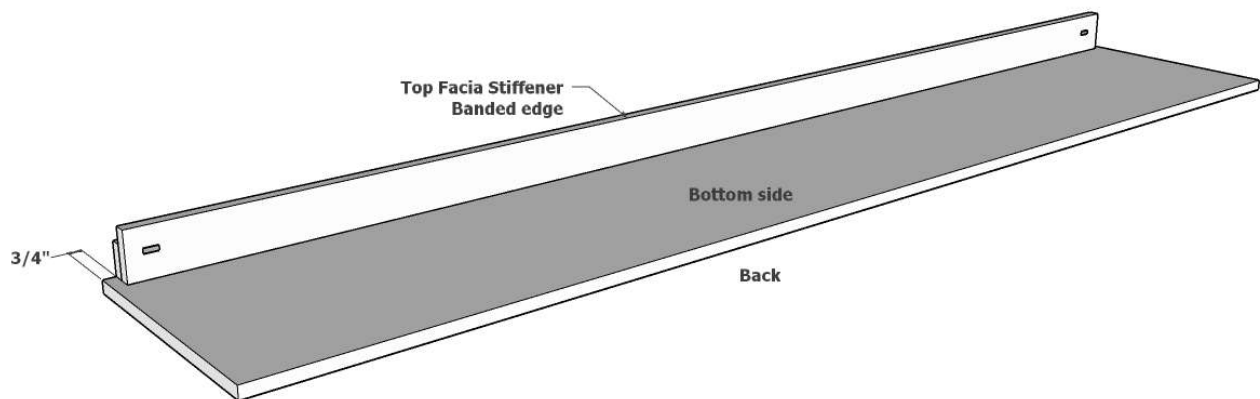

Figure 2-2

2-3 Attach the Top Rear Stiffener (F-1) to the back using glue and 1-1/2" Pocket Screws. Clamps can be used to hold the board in place and to keep slipping from occurring while screws are being inserted. Make sure the banded edge is out (up in this orientation) and the pockets are facing toward the back. This will be 3/4" off each side as in the previous two steps. **Change using 1 1/2" Verticals: Measurements should be 1 1/2" instead of 3/4".**

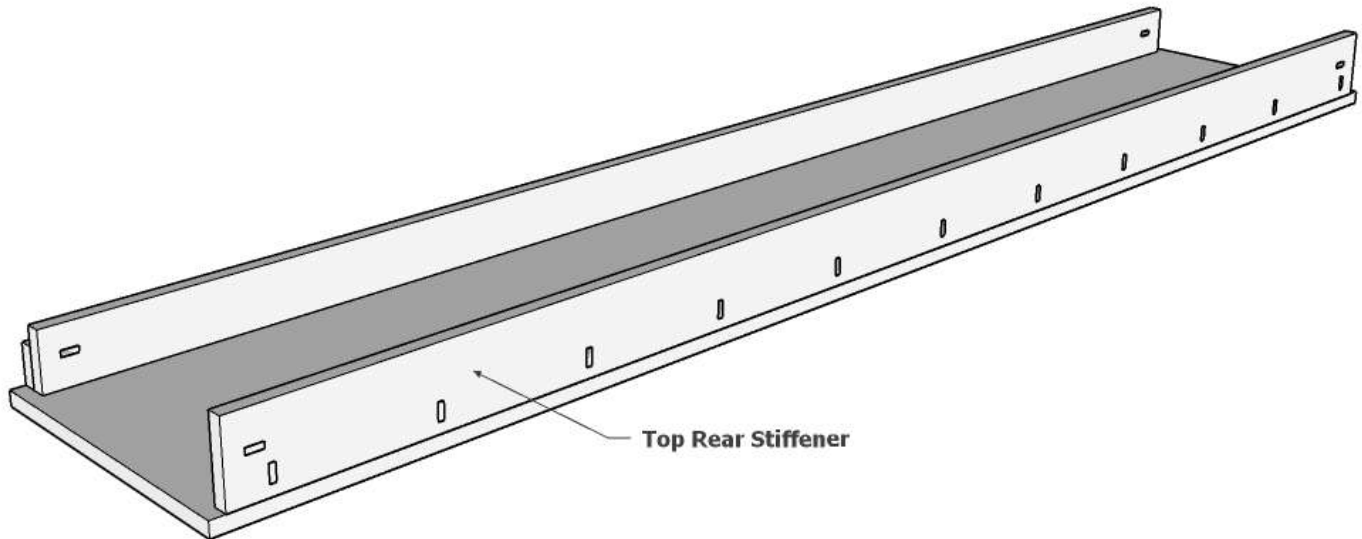

Figure 2-3

2-4 Add the Top Cleats (K) to the Top Panel in between the Top Rear Stiffener and the Top Facia Stiffener using glue and 1 1/2" screws. They should be aligned with the ends of the Top Rear Stiffener and the Top Facia Stiffener.

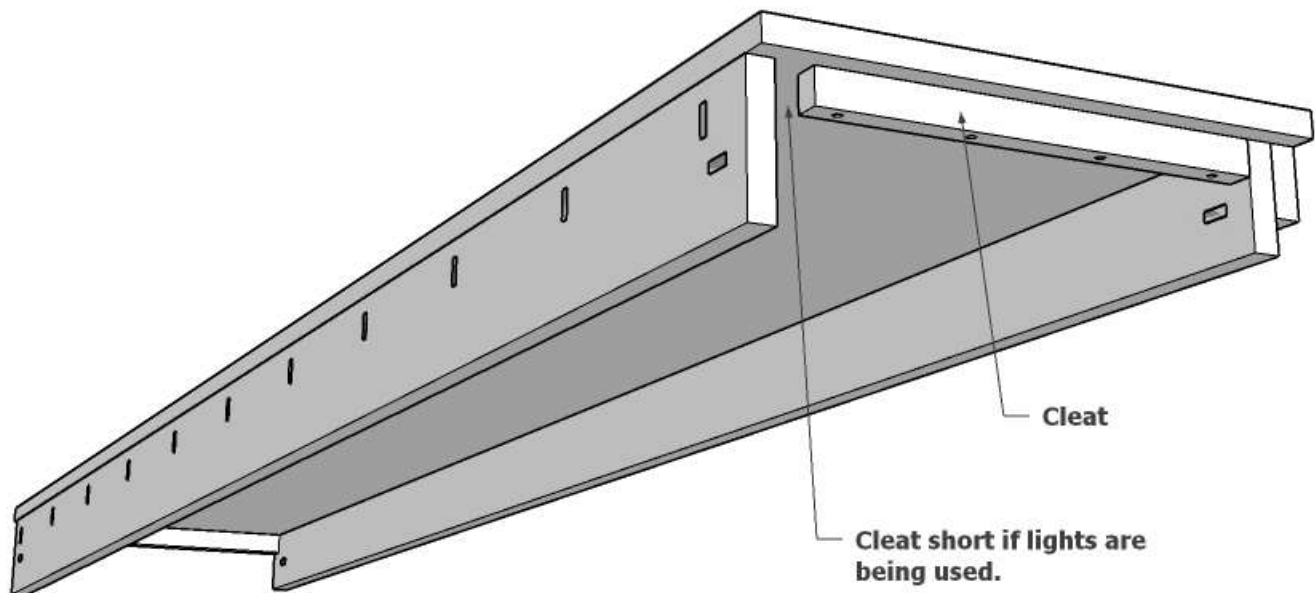

Figure 2-3

2-5 Drill holes in cleats. From the inside, drill 5 holes on each side. Drill these about 5/8" from the Top Panel (slightly off center) and from the following estimated points:

-(1) About 1/2" from each end.

-(2) Center.

-(3) Center between the first hole and the center hole.

Repeat for the other side.

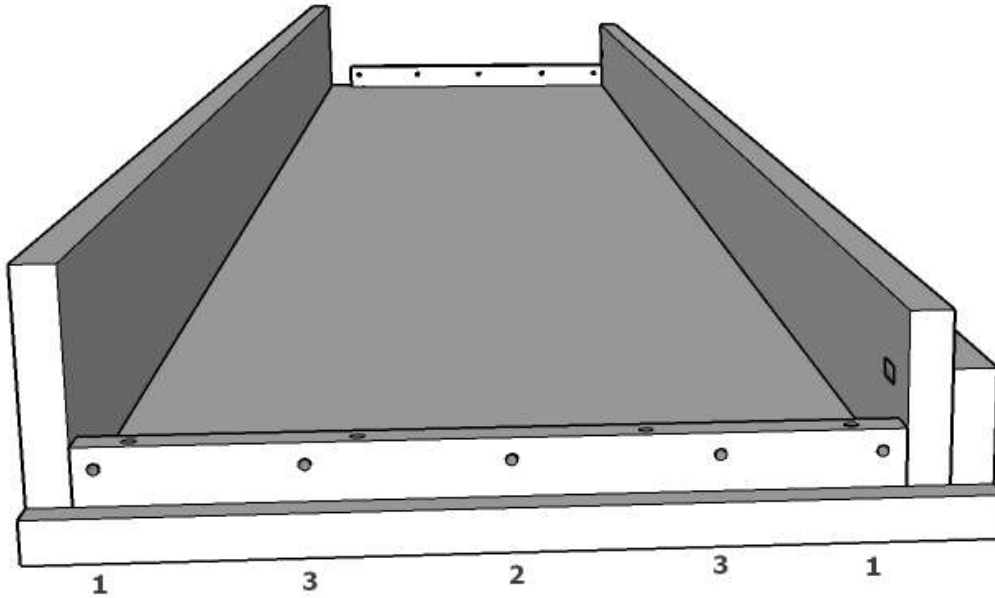

# Lights

Modifications for versions with lights (Skip these steps if no lights)

- Groove was cut in the back of the Left Side Panel (B).
- Pocket was cut at the top/back/inside of that same Left Side Panel (B)

If you have lights you have the following extra pieces

2 - 6" x 1" Cleats

1 - 83  $\frac{3}{8}$ " x 13  $\frac{5}{8}$ " Queen (78  $\frac{3}{8}$ " x 13  $\frac{5}{8}$ " twin or full) Light Panel

All your lights, control box and wiring.

L-1 The left cleat will be short with the gap along the back.

L-2 Add cleats to the header, by placing them under the Top Panel and against the Top Facia Stiffener for the front and the Top Panel and Rear Stiffener on the back. Center them on the length. Attach with 1  $\frac{1}{2}$ " screws.

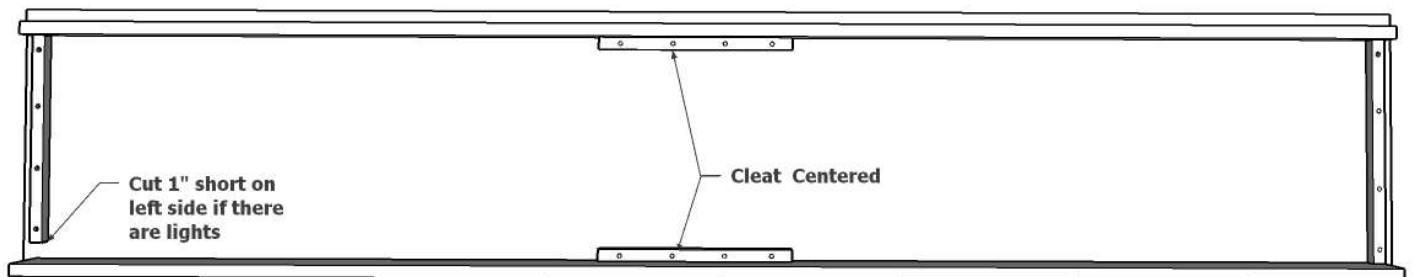
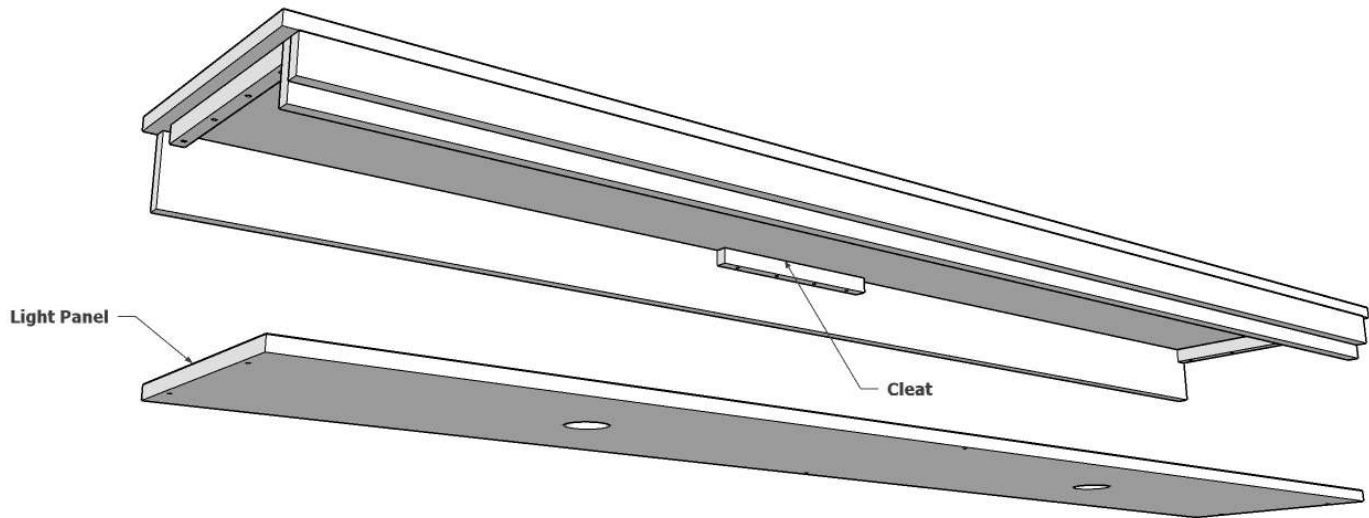

Bottom View

L-3 Drill and countersink holes in the Light Panel. These should be 3/8" off the edge. One centered on the front and back edge. Two on each end 2 1/2" From the front and back. .

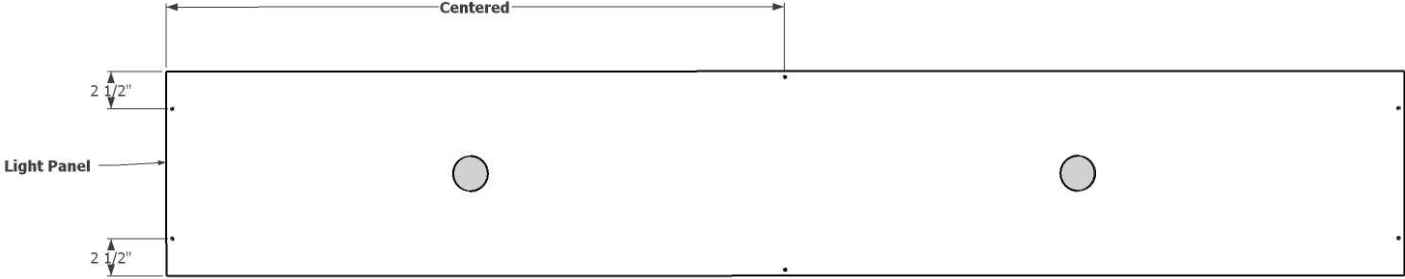

Your header is now complete!

### Step 3: Attach the Head Board Stiffener (I) to the Head board (H).

3-1 Center the Head Board Stiffener on the back side of the Head Board. Glue and nail it down using 1 ¼” nails. Note: Some applications may have all pockets on the Head Board panel. See Figure 3-1

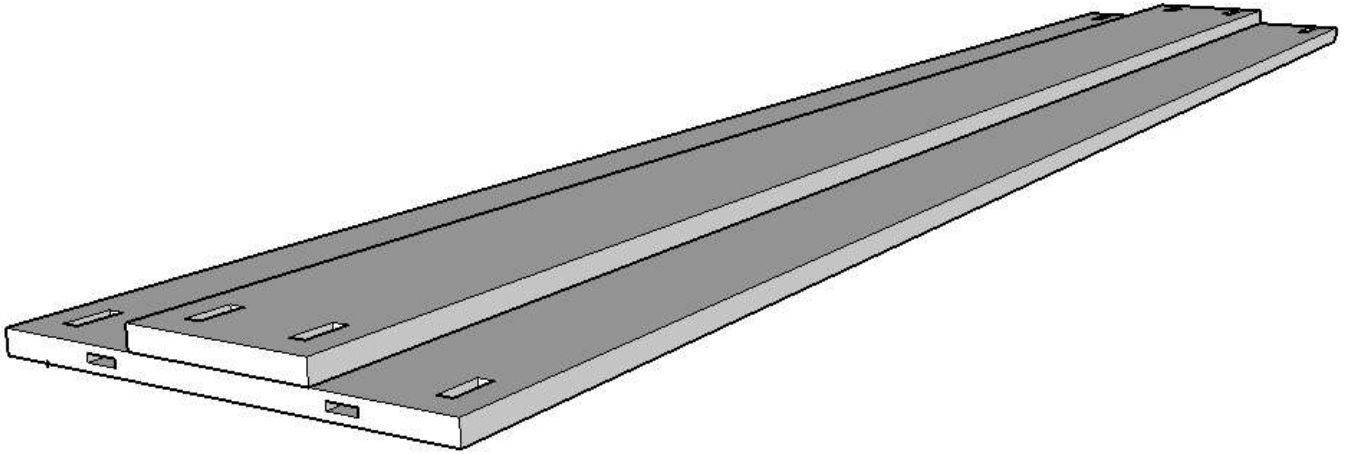

### Step 3: Finish all components

-Finish both sides of all components.

*Tip: By placing pieces like the verticals, headboard and header on legs made from scrap material, you can finish both sides at the same time and save time flipping.*

## Install the Murphy Bed

### Step 4: Mount the Lift Mechanism

4-1: The left and right mechanism hole pattern will line up with the hole pattern on the Side Panel (B). The bolts will be fed through the side that has the counter sinks drilled.

4-2 Hole A will not have a standard nut. It is either a threaded hole or it will use a disk like bolt “Arm Lock Stop”. Get Hole A started.

4-3 Insert the bolt in the other holes and loosely tighten onto the nutes.

4-4 Once all are in place securely tighten using the Allen Wrench provided and a ½” wrench.

## Step 5: Install the springs on the Lift Mechanism

### SPRING APPLICATION CHART

Please Note: These are recommendations only. Actual number of springs required will depend on the total weight of the bed face unit including the mattress and all bedding

BED SIZE	STANDARD FACE (NO DESK)	STANDARD FACE (ADDED DESK)
Single/Twin	4 Springs Vertical (3 Horizontal)	5 Springs Vertical (4 Horizontal)
Double/Full	5 Springs Vertical (4 Horizontal)	6 Springs Vertical (5 Horizontal)
Queen	6 Springs Vertical (5 Horizontal)	7 Springs Vertical (6 Horizontal)
King	8 Springs Vertical	9 Springs Vertical

After you have completed installing and checking the operation of your bed, you may find it necessary to add or remove springs to achieve the correct lift effort of between 5 to 10 pounds.

There are nine locations for springs. If the bed requires an even number of springs, do not use the center hole (#5 from the top). If the bed requires an odd number of springs, start with the center hole (#5 from the top) and work outward in both directions evenly.

Hook the springs so the open ends are facing outward. You may have to gently pry up the tension arm and slide the spring under and snap them into place in the proper hole, matching the same numbered hole from the top of the mechanism back plate. You should have an equal number of springs on each side of the center hole. Use the same number of springs and the same layout on both the left and right mechanisms.

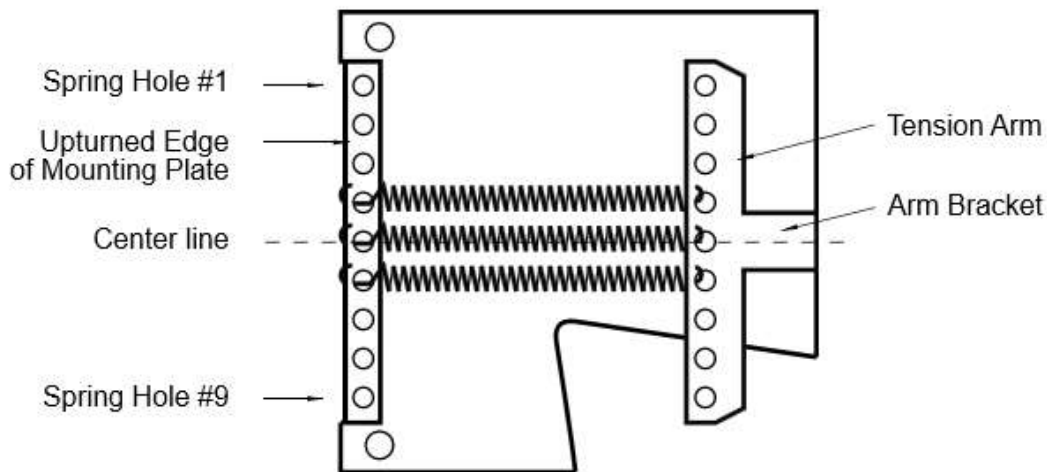

## Step 6: Assemble the Bed Cabinet

- If possible, the Bed Cabinet should be assembled in the room where it will be used.
- The following installation will be done with the bed face down on the floor.

Place the verticals finished edge down and dowel holes toward the inside on a clean floor. You may even lay a soft blanket down to protect the finish from being scratched.

### **Headboard installation**

6-1: Insert the headboard dowels into the ends of the headboard (two on each side). No need to measure, we've taken that step out of you. With the pocket screw holes facing toward the back, insert the headboard dowels into the side of the verticals. Secure with 1 ½" screws (4 each side).

6-2: Use Angle Brackets to assemble Bottom Rear Stiffener and Bottom Kick & Kick Stiffener in position shown in Figure 6-1 and Figure 6-2. Use two Angle Brackets on each end. Attaching using supplied ¾" screws.

NOTE: The Bottom Rear Stiffener can be moved closer to the front if there is a cutout for base molding on the back of the verticals.

IF LIGHTS Run the wiring up the Left Side Panel. Leave about 6" of cord on the top of female end of the black cord with the tilt switch. Lightly tap the cord in the groove with a hammer.

6-3: Attach header as shown in Figure 6-2. Be sure back edge of the header is flush with Front and top of Side Panels. Attach with 1 ½" supplied screws.

6-4: Put 1 ½" screws in the pockets that are in the Top Rear stiffener and the Top Facia Stiffener.



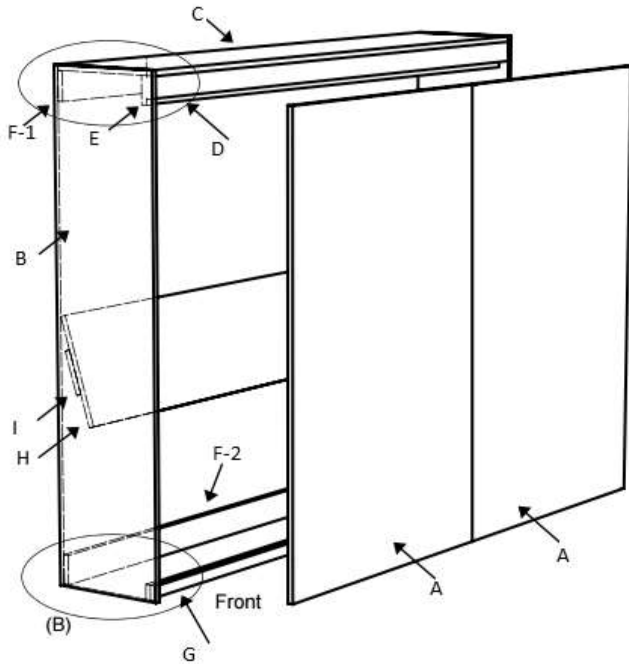

Figure 6-1 **Brackets not shown in the drawing**

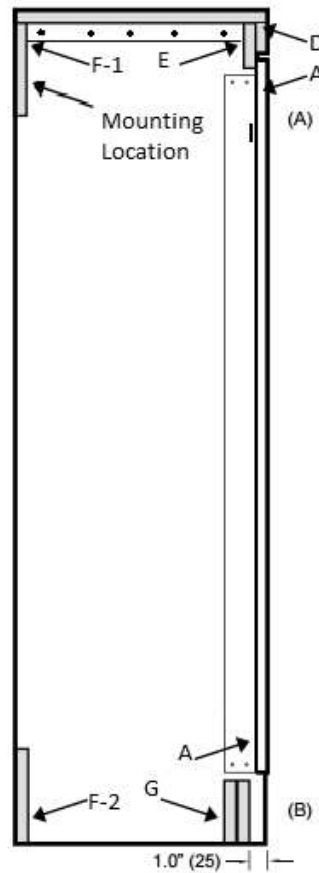

Figure 6-2

**IF LIGHTS** | After the header is installed add the lights to the Light Bar. You may have to unplug them from each other to get them in the cutouts. With the plug side to the left plug the lights into the Black Cord installed in the vertical. Continue pushing the light bar into place on the underside of the Header. Screw into place with 1-½" screws provided. Careful not to pinch any wires.

## Step 7: Attach Bed Cabinet Securely to Wall

We cut out for your base molding so you don't have to remove base molding off the wall. If our cutout was not large enough more may need to be done. Use a jigsaw to perform this task.

### 7-1: Find Studs

Prior to placing the cabinet against the wall, locate 3 studs or other wall frame members at the level of the Top Panel (top of bed). Alert: The cabinet must be secured to studs or other wall structural members. If the wall is not a wood stud wall, use metal stud screws, toggle bolts or concrete expansion bolts if necessary.

### 7-2: Attach to wall

Now that the cabinet is square and plumb, **pre-drill hole in the Top Rear Stiffener at the stud location Secure with 3" screws. Repeat this for two other stud locations.** (see Drawing 9. but instead of brackets you'll drill through the back board on the header). See figure 6-2.

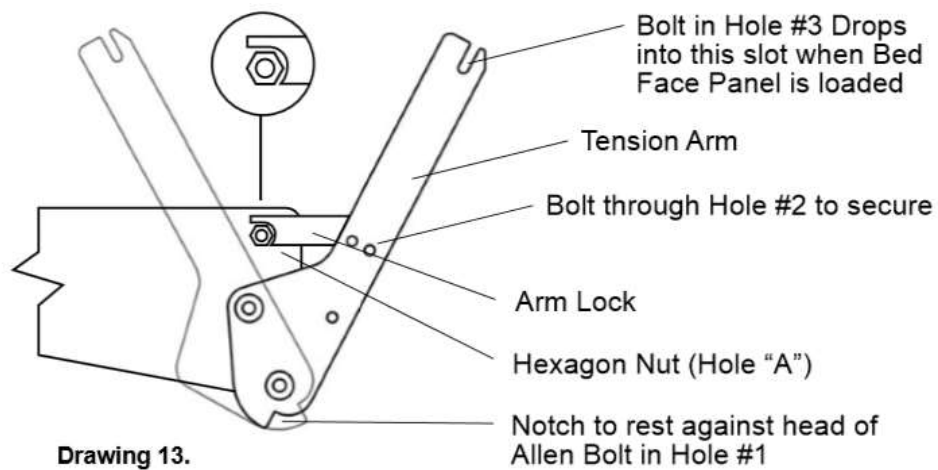

Holding one foot against the bottom front edge of the side panel and using the 13" (330mm) PVC tube, lever the tension arm out until you can set the arm lock to the hex nut at the hole A (see drawing 13.). This is the hex nut at the top front corner of the mechanism.

*Tip: If you set the "Arm Lock" on top of the bolt before you pull the Tension Arm back it will fall into place. Do not put your fingers back there while pulling it back.!*

*Caution: If possible have a helper assist in the setting of the mechanism and loading of the bed face panel. DO NOT reach behind the tension arm when you are doing the setting procedure.*

## Step 8: Install the Bed Face Panel Unit

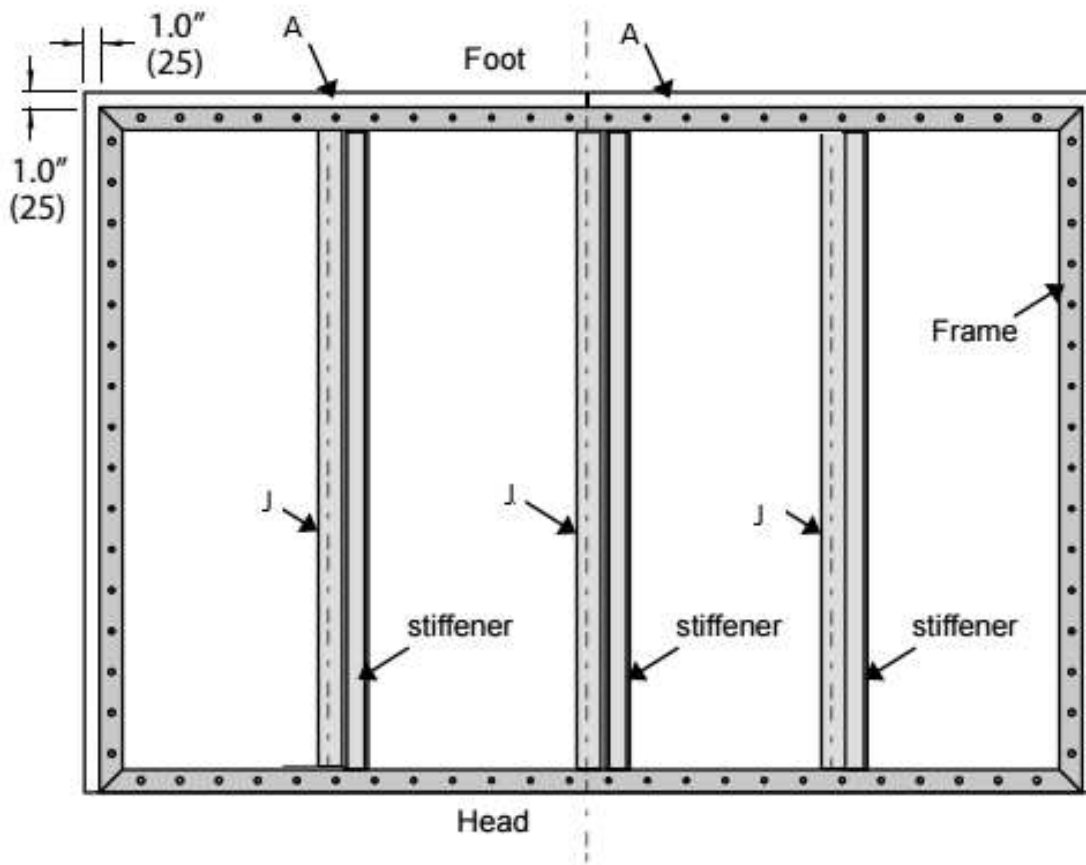

**Figure 8-1**

8-1 Lay the Bed Face Panels down on a non-scratch surface such as a carpet or blanket.

8-2: Completely assemble the 4 Frame Sections with the corner brackets and the 3/16"x1/2" (M5x12mm) black bolts provided. Refer to Drawing 17 below to properly place the leg stops at outer right and left bottom holes at the foot of the bed frame.

8-3: Position the bed frame on the bed face panels. With the Head Frame section flush with the head end of the Bed Face Panels. Refer to Figure 8-1. Carefully attach the Bed Frame so it is centered on the Bed Face Panels; you will have approximately 1" (25mm) space from the bed frame to the panel edges right and left and at the bed foot.

Note: It is very important to have the Bed Frame centered on the Bed Face Panels.

Any error will be noticed in the vertical sight lines when the bed is closed.

8-4: Three steel stiffeners are provided for all beds (5 for King). These notched stiffeners should be located and attached to divide the Bed Face length into four Sections. Locate them approximately 1 1/2" from the seam of each pane. This will leave room for the Panel Connectors (J). Use caution not to damage raised panels by putting screws in recessed areas.

8-5: Attach the Panel Connectors (J) to support the seams. They should fit against the stiffeners installed in step 7-4.

8-6: Attach the Nylon Web Strap approximately 18" (460mm) down from the foot of the bed and 6" (150mm) in from the sides, for tucking in sheets. The Straps help secure the mattress in the vertical position (see drawing above)

8-8: From hardware card 2, insert a Allen Head Bolts through Hole #1 (6 3/4" from end of side frame) on both left and right side frames (see Drawing 14).

8-8 Also Inserted two 5/16" (M8x20mm) Hex Head Bolts from the outside of the frame through Hole #3. We have left these loose.

8-9 Stand the Bed Face Panel in vertical position between the tension arms, lift evenly until the bolt in Hole #3 drops in the slotted end of each tension arm. Gently tilt the bed face toward you until the Allen Bolts in Hole #1 are completely seated in the bottom notch of the tension arms. Insert the remaining 5/16" (8mm) Hex Head Bolts through tension arms into Holes #2 and fasten with 5/16" (8mm) Nylock Nuts; securely tighten these and the nuts on Hole #3.

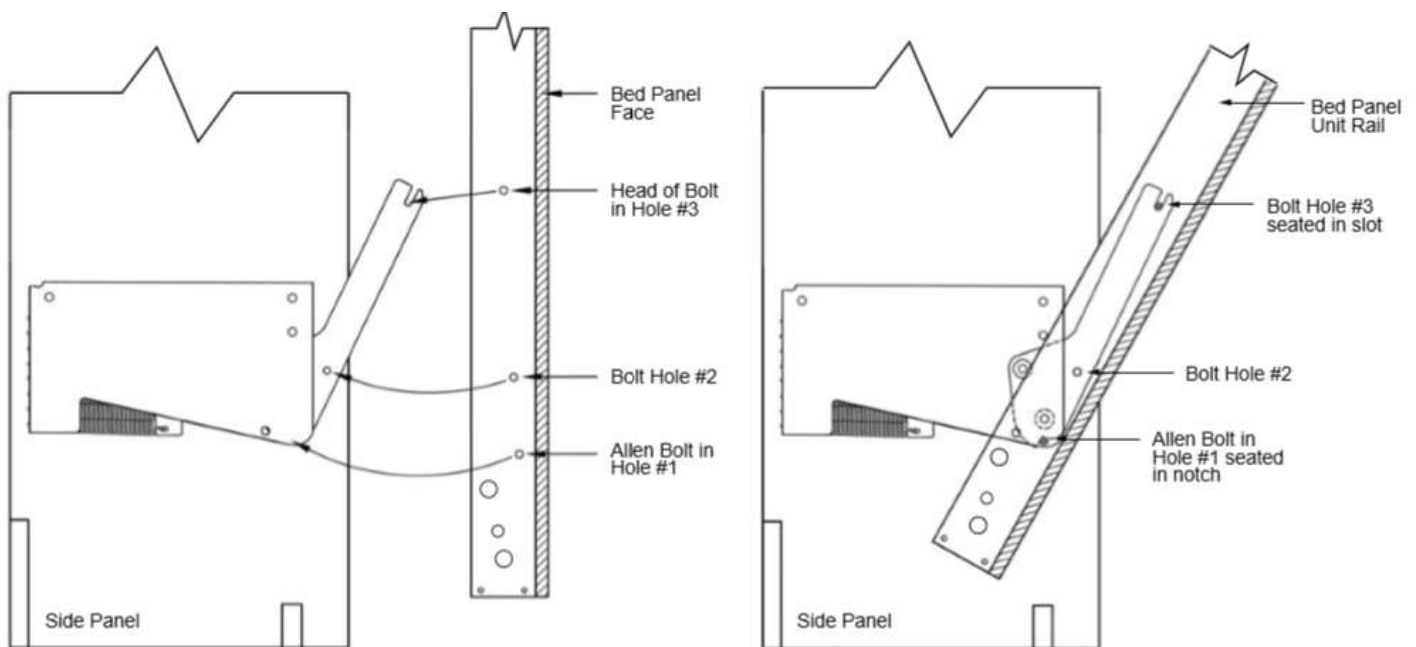

**Drawing 14.**

**Drawing 15.**

8-10 When all bolts are securely tightened, you may tilt the panel outward to approximately 45 degrees to release the arm locks. You will hear a click as they disengage.

**Caution:**

Hold the Face Panel securely, Do Not let it slam shut. Balance is not achieved until the mattress is loaded in the bed.

Leveling of the bed cabinet is essential. Check the level both side to side and front to back. Proper leveling will facilitate proper closure and exact sight lines of the fit of the Face Panel to the Cabinet.

## Step 9: Install Handle = Legs - Mechanism Covers - Mattress

(NOTE: ON A TWIN AND FULL SIZE WITH DESK, THE DESK WILL BE THE LEG. Skip these steps)

9-1 Position and secure handles for ease of operation. Measure down approximately 36" (914mm) from the panel top to the top of the handles.

9-2 Install legs with the washers on the inside of the Rails and the Nylon washer on the outside. Tighten nut to have a small amount of friction when leg assembly is rotated from the up to down position.

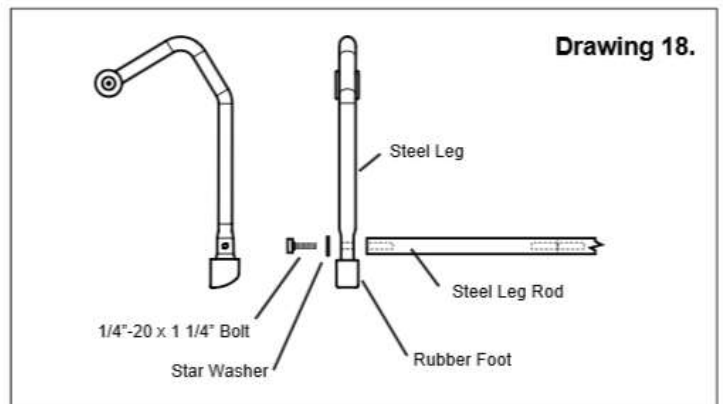
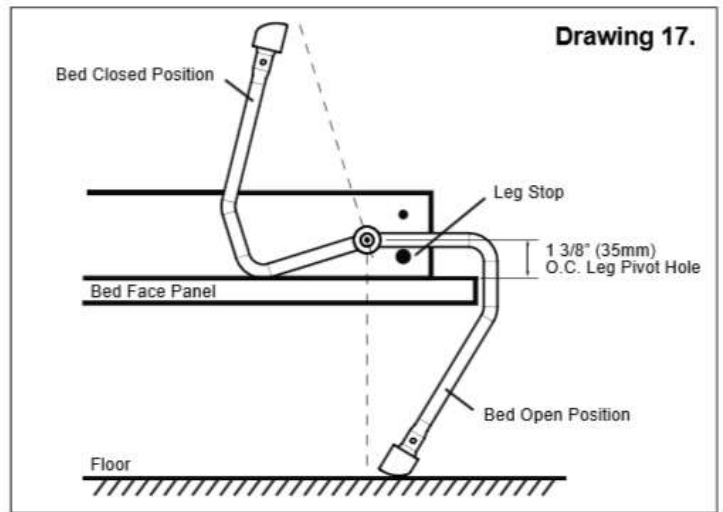
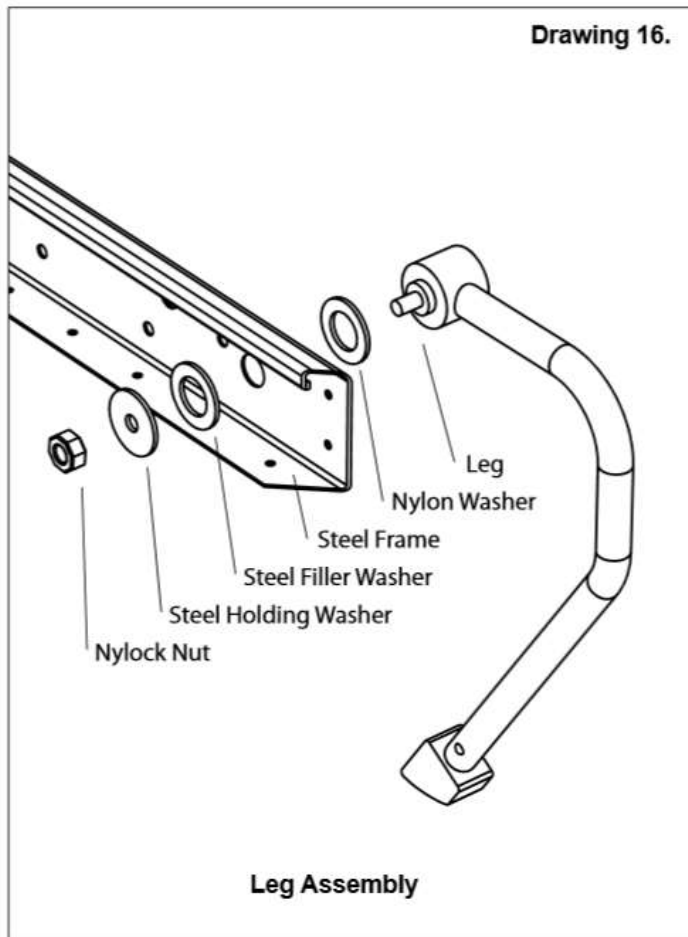

9-3 Install leg connector rod between legs and secure with 1/4"x1 1/4" (M4x32mm) Hex head bolts and star washers. Be sure they are securely tightened so not to become loose.

9-4 Install the mattress and secure with previously installed Nylon Straps.

9-5 Snap the powder coated steel mechanism covers in place - secure with #8x1 1/4" (M4x32mm) black wood screws through the standoff on the backer plate

# Complete Bed Assembly

Follow up to Initial Assembly

Check that the Bed Cabinet is level and square so the Bed Face has equal clearance of the Cabinet on both sides, top to bottom. If the Cabinet is leaning to one side, nudge it at the floor level. If the top is uneven, place shims under the Side Panels. If bed is too heavy to operate easily or slams shut, remove the Bed Face Panel and add or subtract springs. At this time, you may decide to use one more or less spring(s) on the left or right side Lift Mechanism. *Vertical example is shown but applies the horizontal unit as well.*

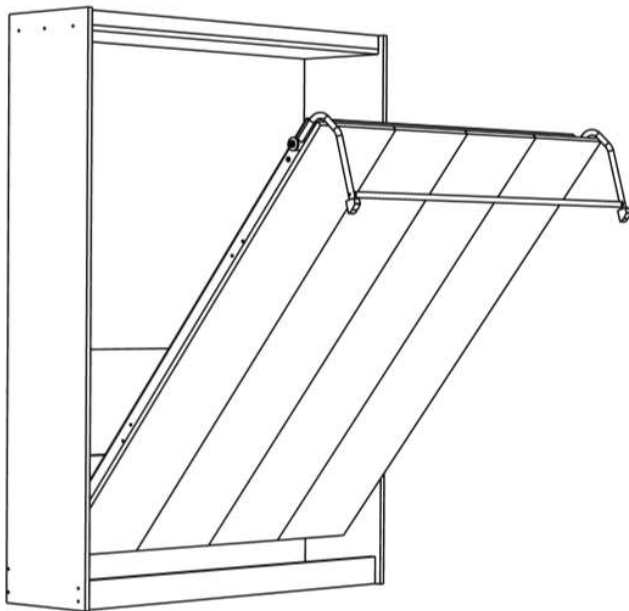

Right Side  
Looking through Side Panel.

## Light Option

If you have light options you'll have the following extra parts:

- (2) 1" x 13 13/16" cleats.
- 83 3/8" x 13 5/8" Queen (78 3/8" x 13 5/8" twin or full) Light Panel
- Touch Plate
  - (2) 3/4" screws for plate
- Control Box
  - (2) 1-1/2" screws for Control Box
- Cord with Tilt Switch
- (2) LED Lights
  - Lights should be connected with a connector wire and the mail plug on one end.

Modifications that were made for this bed

- Groove was cut in the back of the Left Side Panel (B).
- Pocket was cut at the top/back/inside of that same Left Side Panel (B)

### Step L-1

After Step 2-4 Add the extra 2" x 13-13/16" cleats to the underside of the header. These will be placed center one in the front and one in the back and mounted (4) 1-1/2" screws. The front one will go against the Top Face Stiffener and the screw will run into the Top Panel. The back cleat will go against the Top Rear Stiffener and the screws will run into the Top Panel.

Before Step 6-3 (mounting the header) run the wiring up the Left Side Panel. Leave about 6" of cord on the top of female end of the black cord with the tilt switch. Lightly tap the cord in the groove with a hammer.

Continue with step 6-4 with the header.

After the header is installed add the lights to the Light Bar. You may have to unplug them from each other to get them in the cutouts. With the plug side to the left plug the lights into the Black Cord installed in the vertical. Continue pushing the light bar into place on the underside of the Header. Screw into place with 1-1/2" screws provided. Careful not to pinch any wires.